

LM2587 4-V To 40-V, 5-A Step-Up Wide V_{IN} Flyback Regulator

1 Features

- Requires Few External Components
- Family of Standard Inductors and Transformers
- NPN Output Switches 5 A, Can Stand Off 65 V
- Wide Input Voltage Range: 4 V to 40 V
- Current-mode Operation for Improved Transient Response, Line Regulation, and Current Limit
- 100-kHz Switching Frequency
- Internal Soft-Start Function Reduces In-rush Current During Start-up
- Output Transistor Protected by Current Limit, Undervoltage Lockout, and Thermal Shutdown
- System Output Voltage Tolerance of $\pm 4\%$ Maximum Over Line and Load Conditions
- Create a Custom Design Using the LM2587 With the [WEBENCH® Power Designer](#)

2 Typical Applications

- Flyback Regulator
- Multiple-Output Regulator
- Simple Boost Regulator
- Forward Converter

3 Description

The LM2587 series of regulators are monolithic integrated circuits specifically designed for flyback, step-up (boost), and forward converter applications. The device is available in 4 different output voltage versions: 3.3 V, 5 V, 12 V, and adjustable.

Requiring a minimum number of external components, these regulators are cost effective, and simple to use. Included in the datasheet are typical circuits of boost and flyback regulators. Also listed are selector guides for diodes and capacitors and a family of standard inductors and flyback transformers designed to work with these switching regulators.

The power switch is a 5-A NPN device that can stand-off 65 V. Protecting the power switch are current and thermal limiting circuits, and an undervoltage lockout circuit. This IC contains a 100 kHz fixed-frequency internal oscillator that permits the use of small magnetics. Other features include soft-start mode to reduce in-rush current during start up, current mode control for improved rejection of input voltage and output load transients and cycle-by-cycle current limiting. An output voltage tolerance of $\pm 4\%$, within specified input voltages and output load conditions, is ensured for the power supply system.

Device Information⁽¹⁾

PART NUMBER	PACKAGE	BODY SIZE (NOM)
LM2587	DDPAK/ TO-263 (5)	10.16 mm x 8.42 mm
	TO-220 (5)	14.986 mm x 10.16 mm

(1) For all available packages, see the orderable addendum at the end of the data sheet.

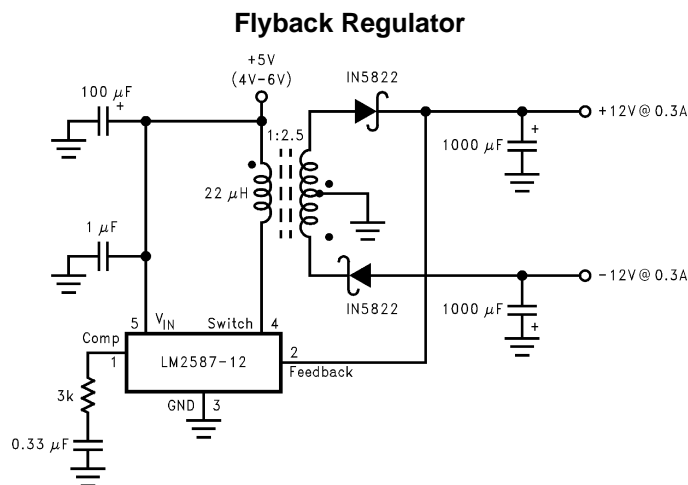

Table of Contents

1 Features	1	7.2 Functional Block Diagram	13
2 Typical Applications	1	7.3 Feature Description	14
3 Description	1	8 Application And Implementation	15
4 Revision History	2	8.1 Application Information	15
5 Pin Configurations	3	8.2 Typical Applications	15
6 Specifications	4	8.3 Additional Application Examples	27
6.1 Absolute Maximum Ratings	4	9 Layout	28
6.2 ESD Ratings	4	9.1 Layout Guidelines	28
6.3 Recommended Operating Ratings	4	9.2 Layout Example	28
6.4 Thermal Information	5	9.3 Heat Sink/Thermal Considerations	28
6.5 Electrical Characteristics: 3.3 V	5	10 Device and Documentation Support	31
6.6 Electrical Characteristics: 5 V	6	10.1 Device Support	31
6.7 Electrical Characteristics: 12 V	6	10.2 Receiving Notification Of Documentation Updates	31
6.8 Electrical Characteristics: Adjustable	7	10.3 Community Resources	31
6.9 Electrical Characteristics: All Output Voltage Versions	7	10.4 Trademarks	31
6.10 Typical Characteristics	9	10.5 Electrostatic Discharge Caution	31
7 Detailed Description	12	10.6 Glossary	32
7.1 Overview	12	11 Mechanical, Packaging, and Orderable Information	32

4 Revision History

NOTE: Page numbers for previous revisions may differ from page numbers in the current version.

Changes from Revision D (April 2013) to Revision E	Page
• Editorial changes only, no technical revisions; add links for WEBENCH	1

Changes from Revision C (April 2013) to Revision D	Page
• Changed layout of National Data Sheet to TI format	30

5 Pin Configurations

**NDH Package
5-Pin TO-220
Top View, Bent Staggered Leads**



**KTT Package
5-Pin DDPAK/TO-263
Top View**

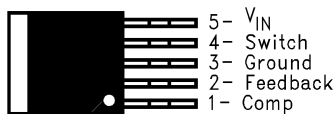

**NDH Package
5-Pin TO-220
Side View, Bent Staggered Leads**



**KTT Package
5-Pin DDPAK/TO-263
Side View**



6 Specifications

6.1 Absolute Maximum Ratings

over operating free-air temperature range (unless otherwise noted)⁽¹⁾⁽²⁾

Input Voltage		$-0.4V \leq V_{IN} \leq 45V$
Switch Voltage		$-0.4V \leq V_{SW} \leq 65V$
Switch Current ⁽³⁾		Internally Limited
Compensation Pin Voltage		$-0.4V \leq V_{COMP} \leq 2.4V$
Feedback Pin Voltage		$-0.4V \leq V_{FB} \leq 2 V_{OUT}$
Storage Temperature Range		$-65^{\circ}C$ to $+150^{\circ}C$
Lead Temperature	(Soldering, 10 sec.)	$260^{\circ}C$
Maximum Junction	Temperature ⁽⁴⁾	$150^{\circ}C$
Power Dissipation ⁽⁴⁾		Internally Limited

- (1) Absolute Maximum Ratings indicate limits beyond which damage to the device may occur. Operating ratings indicate conditions the device is intended to be functional, but device parameter specifications may not be specified under these conditions. For specifications and test conditions see .
- (2) If Military/Aerospace specified devices are required, contact the Texas Instruments Sales Office/ Distributors for availability and specifications.
- (3) Note that switch current and output current are not identical in a step-up regulator. Output current cannot be internally limited when the LM2587 is used as a step-up regulator. To prevent damage to the switch, the output current must be externally limited to 5A. However, output current is internally limited when the LM2587 is used as a flyback regulator (see the section for more information).
- (4) The junction temperature of the device (T_J) is a function of the ambient temperature (T_A), the junction-to-ambient thermal resistance (θ_{JA}), and the power dissipation of the device (P_D). A thermal shutdown will occur if the temperature exceeds the maximum junction temperature of the device: $P_D \times \theta_{JA} + T_{A(MAX)} \geq T_{J(MAX)}$. For a safe thermal design, check that the maximum power dissipated by the device is less than: $P_D \leq [T_{J(MAX)} - T_{A(MAX)}] / \theta_{JA}$. When calculating the maximum allowable power dissipation, derate the maximum junction temperature—this ensures a margin of safety in the thermal design.

6.2 ESD Ratings

			VALUE	UNIT
$V_{(ESD)}$	Electrostatic discharge (minimum)	Human-body model (HBM), per ANSI/ESDA/JEDEC JS-001 ⁽¹⁾ ($C = 100$ pF, $R = 1.5$ k Ω)	2000	V

- (1) JEDEC document JEP155 states that 500-V HBM allows safe manufacturing with a standard ESD control process.

6.3 Recommended Operating Ratings

Supply Voltage	$4V \leq V_{IN} \leq 40V$
Output Switch Voltage	$0V \leq V_{SW} \leq 60V$
Output Switch Current	$I_{SW} \leq 5.0A$
Junction Temperature Range	$-40^{\circ}C \leq T_J \leq +125^{\circ}C$

6.4 Thermal Information

THERMAL METRIC ⁽¹⁾⁽²⁾		LM2585		UNIT
		KTT (DDPAK/TO-263)	NDH (TO-220)	
		5 PINS	5 PINS	
R _{θJA}	Junction-to-ambient thermal resistance	56 ⁽³⁾	65 ⁽⁴⁾	°C/W
		35 ⁽⁵⁾	45 ⁽⁶⁾	
		26 ⁽⁷⁾	—	
R _{θJC}	Junction-to-case thermal resistance	2	2	°C/W

- (1) For more information about traditional and new thermal metrics, see the [Semiconductor and IC package thermal metrics application report](#).
- (2) External components such as the diode, inductor, input and output capacitors can affect switching regulator performance. When the LM2587 is used as shown in [Figure 61](#) and [Figure 62](#), system performance will be as specified by the system parameters.
- (3) Junction-to-ambient thermal resistance for the 5 lead TO-263 mounted horizontally against a PC board area of 0.136 square inches (the same size as the TO-263 package) of 1 oz. (0.0014 in. thick) copper.
- (4) Junction-to-ambient thermal resistance (no external heat sink) for the 5 lead TO-220 package mounted vertically, with ½ inch leads in a socket, or on a PC board with minimum copper area.
- (5) Junction-to-ambient thermal resistance for the 5 lead TO-263 mounted horizontally against a PC board area of 0.4896 square inches (3.6 times the area of the TO-263 package) of 1 oz. (0.0014 in. thick) copper.
- (6) Junction-to-ambient thermal resistance (no external heat sink) for the 5 lead TO-220 package mounted vertically, with ½ inch leads soldered to a PC board containing approximately 4 square inches of (1oz.) copper area surrounding the leads.
- (7) Junction-to-ambient thermal resistance for the 5 lead TO-263 mounted horizontally against a PC board copper area of 1.0064 square inches (7.4 times the area of the TO-263 package) of 1 oz. (0.0014 in. thick) copper. Additional copper area reduces thermal resistance further. See the thermal model in Switchers Made Simple[®] software.

6.5 Electrical Characteristics: 3.3 V

Specifications with standard type face are for T_J = 25°C, and those in **bold** apply over full **Operating Temperature Range**. Unless otherwise specified, V_{IN} = 5V.

PARAMETER		TEST CONDITIONS	TYP	MIN	MAX	UNIT
SYSTEM PARAMETERS Test Circuit of Figure 61 ⁽¹⁾						
V _{OUT}	Output Voltage	V _{IN} = 4V to 12V I _{LOAD} = 400 mA to 1.75A	3.3	3.17/3.14	3.43/3.46	V
ΔV _{OUT} /ΔV _{IN}	Line Regulation	V _{IN} = 4V to 12V I _{LOAD} = 400 mA	20		50/100	mV
ΔV _{OUT} /ΔI _{LOAD}	Load Regulation	V _{IN} = 12V I _{LOAD} = 400 mA to 1.75A	20		50/100	mV
η	Efficiency	V _{IN} = 12V, I _{LOAD} = 1A	75			%
UNIQUE DEVICE PARAMETERS ⁽²⁾						
V _{REF}	Output Reference Voltage	Measured at Feedback Pin V _{COMP} = 1.0V	3.3	3.242/3.234	3.358/3.366	V
ΔV _{REF}	Reference Voltage Line Regulation	V _{IN} = 4V to 40V	2.0			mV
G _M	Error Amp Transconductance	I _{COMP} = -30 μA to +30 μA V _{COMP} = 1.0V	1.193	0.678	2.259	mmho
A _{VOL}	Error Amp Voltage Gain	V _{COMP} = 0.5V to 1.6V R _{COMP} = 1.0 MΩ ⁽³⁾	260	151/75		V/V

- (1) External components such as the diode, inductor, input and output capacitors can affect switching regulator performance. When the LM2587 is used as shown in [Figure 61](#) and [Figure 62](#), system performance will be as specified by the system parameters.
- (2) All room temperature limits are 100% production tested, and all limits at temperature extremes are specified via correlation using standard Statistical Quality Control (SQC) methods.
- (3) A 1-MΩ resistor is connected to the compensation pin (which is the error amplifier output) to ensure accuracy in measuring A_{VOL}.

6.6 Electrical Characteristics: 5 V

Specifications with standard type face are for $T_J = 25^\circ\text{C}$, and those in **bold** apply over full **Operating Temperature Range**. Unless otherwise specified, $V_{IN} = 5\text{V}$.

PARAMETER		TEST CONDITIONS	TYP	MIN	MAX	UNIT
SYSTEM PARAMETERS Test Circuit of Figure 61 ⁽¹⁾						
V_{OUT}	Output Voltage	$V_{IN} = 4\text{V to }12\text{V}$ $I_{LOAD} = 500\text{ mA to }1.45\text{A}$	5.0	4.80/ 4.75	5.20/ 5.25	V
$\frac{\Delta V_{OUT}}{\Delta V_{IN}}$	Line Regulation	$V_{IN} = 4\text{V to }12\text{V}$ $I_{LOAD} = 500\text{ mA}$	20		50/ 100	mV
$\frac{\Delta V_{OUT}}{\Delta I_{LOAD}}$	Load Regulation	$V_{IN} = 12\text{V}$ $I_{LOAD} = 500\text{ mA to }1.45\text{A}$	20		50/ 100	mV
η	Efficiency	$V_{IN} = 12\text{V}$, $I_{LOAD} = 750\text{ mA}$	80			%
UNIQUE DEVICE PARAMETERS ⁽²⁾						
V_{REF}	Output Reference Voltage	Measured at Feedback Pin $V_{COMP} = 1.0\text{V}$	5.0	4.913/ 4.900	5.088/ 5.100	V
ΔV_{REF}	Reference Voltage Line Regulation	$V_{IN} = 4\text{V to }40\text{V}$	3.3			mV
G_M	Error Amp Transconductance	$I_{COMP} = -30\ \mu\text{A to }+30\ \mu\text{A}$ $V_{COMP} = 1.0\text{V}$	0.750	0.447	1.491	mmho
A_{VOL}	Error Amp Voltage Gain	$V_{COMP} = 0.5\text{V to }1.6\text{V}$ $R_{COMP} = 1.0\ \text{M}\Omega$ ⁽³⁾	165	99/ 49		V/V

- (1) External components such as the diode, inductor, input and output capacitors can affect switching regulator performance. When the LM2587 is used as shown in [Figure 61](#) and [Figure 62](#), system performance will be as specified by the system parameters.
- (2) All room temperature limits are 100% production tested, and all limits at temperature extremes are specified via correlation using standard Statistical Quality Control (SQC) methods.
- (3) A 1-M Ω resistor is connected to the compensation pin (which is the error amplifier output) to ensure accuracy in measuring A_{VOL} .

6.7 Electrical Characteristics: 12 V

Specifications with standard type face are for $T_J = 25^\circ\text{C}$, and those in **bold** apply over full **Operating Temperature Range**. Unless otherwise specified, $V_{IN} = 5\text{V}$.

PARAMETER		TEST CONDITIONS	TYP	MIN	MAX	UNIT
SYSTEM PARAMETERS Test Circuit of Figure 62 ⁽¹⁾						
V_{OUT}	Output Voltage	$V_{IN} = 4\text{V to }10\text{V}$ $I_{LOAD} = 300\text{ mA to }1.2\text{A}$	12.0	11.52/ 11.40	12.48/ 12.60	V
$\frac{\Delta V_{OUT}}{\Delta V_{IN}}$	Line Regulation	$V_{IN} = 4\text{V to }10\text{V}$ $I_{LOAD} = 300\text{ mA}$	20		100/ 200	mV
$\frac{\Delta V_{OUT}}{\Delta I_{LOAD}}$	Load Regulation	$V_{IN} = 10\text{V}$ $I_{LOAD} = 300\text{ mA to }1.2\text{A}$	20		100/ 200	mV
η	Efficiency	$V_{IN} = 10\text{V}$, $I_{LOAD} = 1\text{A}$	90			%
UNIQUE DEVICE PARAMETERS ⁽²⁾						
V_{REF}	Output Reference Voltage	Measured at Feedback Pin $V_{COMP} = 1.0\text{V}$	12.0	11.79/ 11.76	12.21/ 12.24	V
ΔV_{REF}	Reference Voltage Line Regulation	$V_{IN} = 4\text{V to }40\text{V}$	7.8			mV
G_M	Error Amp Transconductance	$I_{COMP} = -30\ \mu\text{A to }+30\ \mu\text{A}$ $V_{COMP} = 1.0\text{V}$	0.328	0.186	0.621	mmho
A_{VOL}	Error Amp Voltage Gain	$V_{COMP} = 0.5\text{V to }1.6\text{V}$ $R_{COMP} = 1.0\ \text{M}\Omega$ ⁽³⁾	70	41/ 21		V/V

- (1) External components such as the diode, inductor, input and output capacitors can affect switching regulator performance. When the LM2587 is used as shown in [Figure 61](#) and [Figure 62](#), system performance will be as specified by the system parameters.
- (2) All room temperature limits are 100% production tested, and all limits at temperature extremes are specified via correlation using standard Statistical Quality Control (SQC) methods.
- (3) A 1-M Ω resistor is connected to the compensation pin (which is the error amplifier output) to ensure accuracy in measuring A_{VOL} .

6.8 Electrical Characteristics: Adjustable

Specifications with standard type face are for $T_J = 25^\circ\text{C}$, and those in **bold type face** apply over full **Operating Temperature Range**. Unless otherwise specified, $V_{IN} = 5\text{V}$.

PARAMETER	TEST CONDITIONS	TYP	MIN	MAX	UNIT	
SYSTEM PARAMETERS Test Circuit of Figure 62 ⁽¹⁾						
V_{OUT}	Output Voltage	$V_{IN} = 4\text{V to } 10\text{V}$ $I_{LOAD} = 300\text{ mA to } 1.2\text{A}$	12.0	11.52/ 11.40	12.48/ 12.60	V
$\frac{\Delta V_{OUT}}{\Delta V_{IN}}$	Line Regulation	$V_{IN} = 4\text{V to } 10\text{V}$ $I_{LOAD} = 300\text{ mA}$	20		100/ 200	mV
$\frac{\Delta V_{OUT}}{\Delta I_{LOAD}}$	Load Regulation	$V_{IN} = 10\text{V}$ $I_{LOAD} = 300\text{ mA to } 1.2\text{A}$	20		100/ 200	mV
η	Efficiency	$V_{IN} = 10\text{V}$, $I_{LOAD} = 1\text{A}$	90			%
UNIQUE DEVICE PARAMETERS ⁽²⁾						
V_{REF}	Output Reference Voltage	Measured at Feedback Pin $V_{COMP} = 1.0\text{V}$	1.230	1.208/ 1.205	1.252/ 1.255	V
ΔV_{REF}	Reference Voltage Line Regulation	$V_{IN} = 4\text{V to } 40\text{V}$	1.5			mV
G_M	Error Amp Transconductance	$I_{COMP} = -30\ \mu\text{A to } +30\ \mu\text{A}$ $V_{COMP} = 1.0\text{V}$	3.200	1.800	6.000	mmho
A_{VOL}	Error Amp Voltage Gain	$V_{COMP} = 0.5\text{V to } 1.6\text{V}$ $R_{COMP} = 1.0\ \text{M}\Omega$ ⁽³⁾	670	400/ 200		V/V
I_B	Error Amp Input Bias Current	$V_{COMP} = 1.0\text{V}$	125		425/ 600	nA

(1) External components such as the diode, inductor, input and output capacitors can affect switching regulator performance. When the LM2587 is used as shown in [Figure 61](#) and [Figure 62](#), system performance will be as specified by the system parameters.

(2) All room temperature limits are 100% production tested, and all limits at temperature extremes are specified via correlation using standard Statistical Quality Control (SQC) methods.

(3) A 1-M Ω resistor is connected to the compensation pin (which is the error amplifier output) to ensure accuracy in measuring A_{VOL} .

6.9 Electrical Characteristics: All Output Voltage Versions⁽¹⁾

Specifications with standard type face are for $T_J = 25^\circ\text{C}$, and those in **bold type face** apply over full **Operating Temperature Range**. Unless otherwise specified, $V_{IN} = 5\text{V}$.

PARAMETER	TEST CONDITIONS	TYP	MIN	MAX	UNIT	
I_S	Input Supply Current	(Switch Off) See ⁽²⁾	11		15.5/ 16.5	mA
		$I_{SWITCH} = 3.0\text{A}$	85		140/ 165	mA
V_{UV}	Input Supply Undervoltage Lockout	$R_{LOAD} = 100\ \Omega$	3.30	3.05	3.75	V
f_O	Oscillator Frequency	Measured at Switch Pin $R_{LOAD} = 100\ \Omega$ $V_{COMP} = 1.0\text{V}$	100	85/75	115/125	kHz
f_{SC}	Short-Circuit Frequency	Measured at Switch Pin $R_{LOAD} = 100\ \Omega$ $V_{FEEDBACK} = 1.15\text{V}$	25			kHz
V_{EAO}	Error Amplifier Output Swing	Upper Limit See ⁽³⁾	2.8	2.6/ 2.4		V
		Lower Limit See ⁽²⁾	0.25		0.40/ 0.55	V
I_{EAO}	Error Amp Output Current (Source or Sink)	See ⁽⁴⁾	165	110/ 70	260/ 320	μA

(1) All room temperature limits are 100% production tested, and all limits at temperature extremes are specified via correlation using standard Statistical Quality Control (SQC) methods.

(2) To measure this parameter, the feedback voltage is set to a high value, depending on the output version of the device, to force the error amplifier output low. Adj: $V_{FB} = 1.41\text{ V}$; 3.3 V: $V_{FB} = 3.8\text{ V}$; 5 V: $V_{FB} = 5.75\text{ V}$; 12 V: $V_{FB} = 13.8\text{ V}$.

(3) To measure this parameter, the feedback voltage is set to a low value, depending on the output version of the device, to force the error amplifier output high. Adj: $V_{FB} = 1.05\text{ V}$; 3.3 V: $V_{FB} = 2.81\text{ V}$; 5 V: $V_{FB} = 4.25\text{ V}$; 12 V: $V_{FB} = 10.2\text{ V}$.

(4) To measure the worst-case error amplifier output current, the LM2587 is tested with the feedback voltage set to its low value (specified in Note 7) and at its high value (specified in Note 8).

Electrical Characteristics: All Output Voltage Versions ⁽¹⁾ (continued)

Specifications with standard type face are for $T_J = 25^\circ\text{C}$, and those in **bold type face** apply over full **Operating Temperature Range**. Unless otherwise specified, $V_{IN} = 5\text{V}$.

PARAMETER		TEST CONDITIONS	TYP	MIN	MAX	UNIT
I_{SS}	Soft Start Current	$V_{FEEDBACK} = 0.92\text{V}$ $V_{COMP} = 1.0\text{V}$	11.0	8.0/ 7.0	17.0/ 19.0	μA
D	Maximum Duty Cycle	$R_{LOAD} = 100\Omega$ See ⁽³⁾	98	93/ 90		%
I_L	Switch Leakage Current	Switch Off $V_{SWITCH} = 60\text{V}$	15		300/ 600	μA
V_{SUS}	Switch Sustaining Voltage	$dV/dT = 1.5\text{V/ns}$		65		V
V_{SAT}	Switch Saturation Voltage	$I_{SWITCH} = 5.0\text{A}$	0.7		1.1/ 1.4	V
I_{CL}	NPN Switch Current Limit		6.5	5.0	9.5	A

6.10 Typical Characteristics

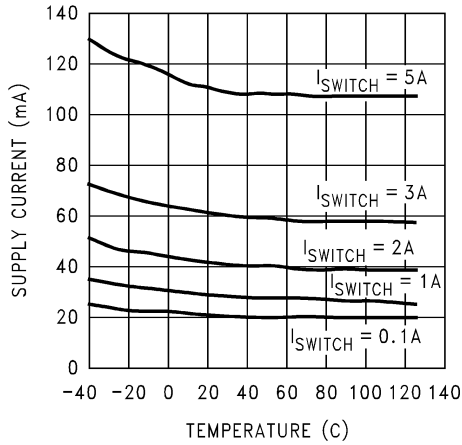

Figure 1. Supply Current vs Temperature

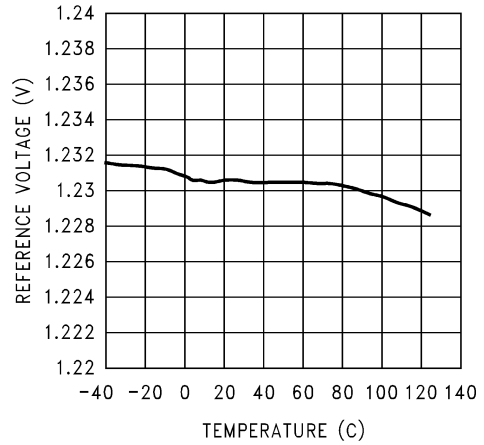

Figure 2. Reference Voltage vs Temperature

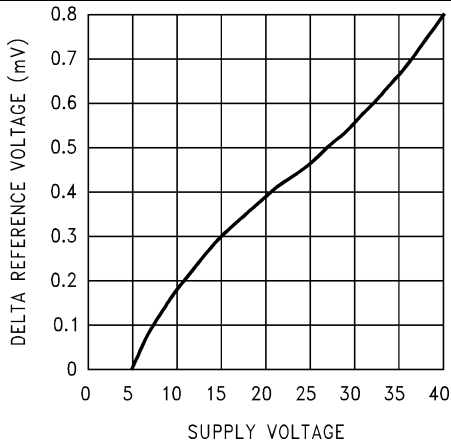

Figure 3. ΔReference Voltage vs Supply Voltage

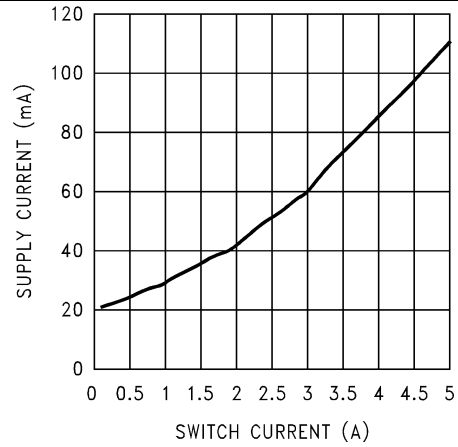

Figure 4. Supply Current vs Switch Current

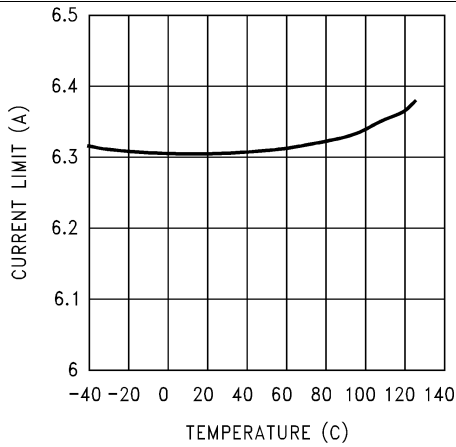

Figure 5. Current Limit vs Temperature

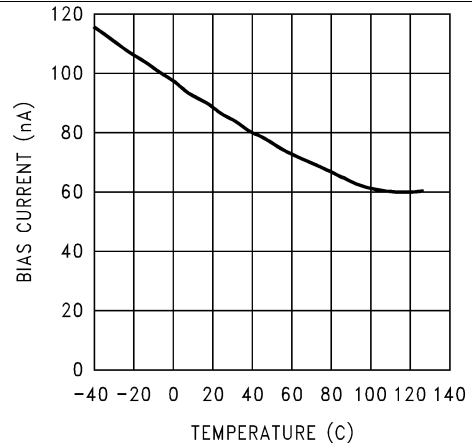

Figure 6. Feedback Pin Bias Current vs Temperature

Typical Characteristics (continued)

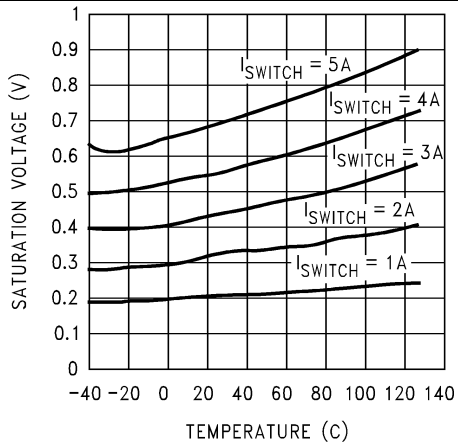

Figure 7. Switch Saturation Voltage vs Temperature

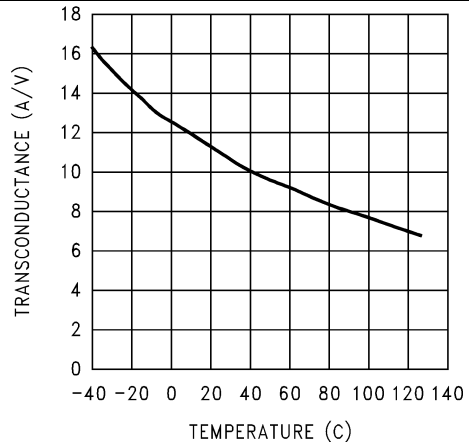

Figure 8. Switch Transconductance vs Temperature

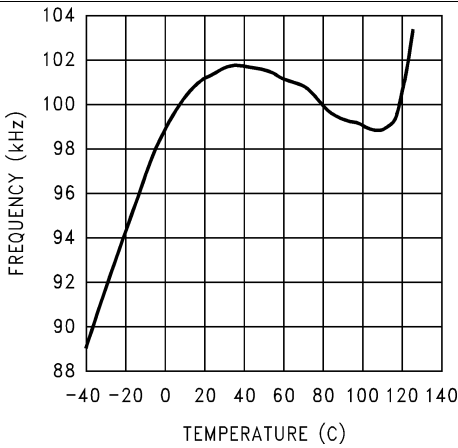

Figure 9. Oscillator Frequency vs Temperature

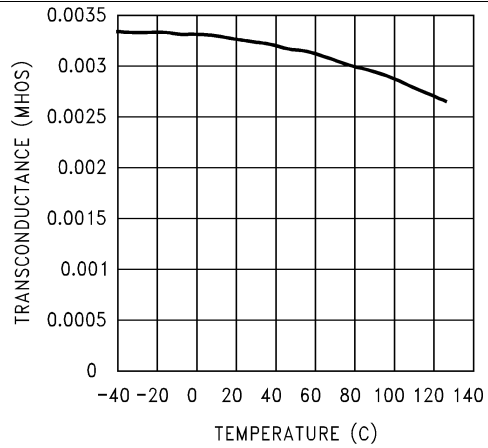

Figure 10. Error Amp Transconductance vs Temperature

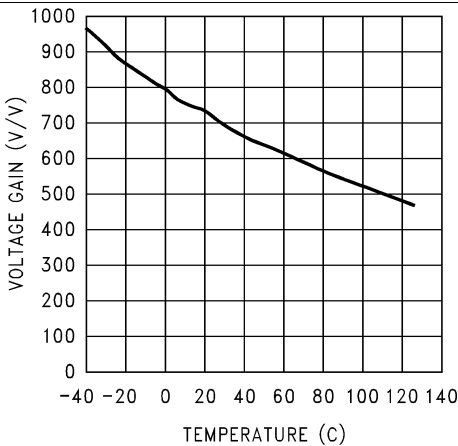

Figure 11. Error Amp Voltage Gain vs Temperature

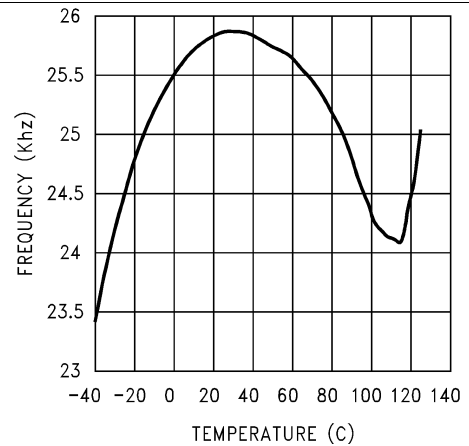
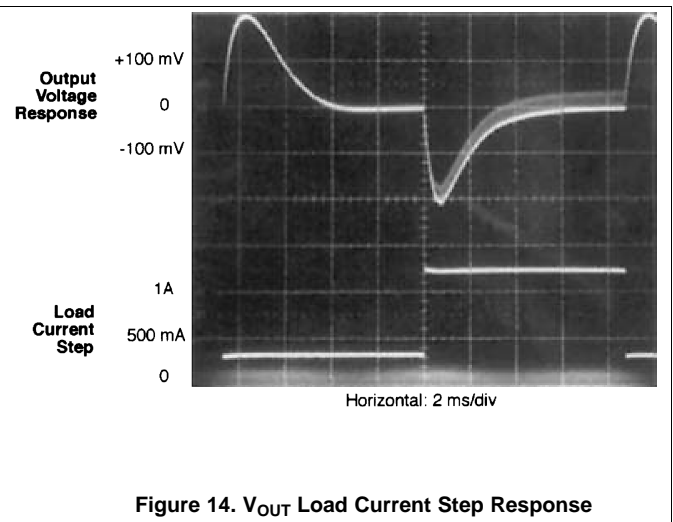
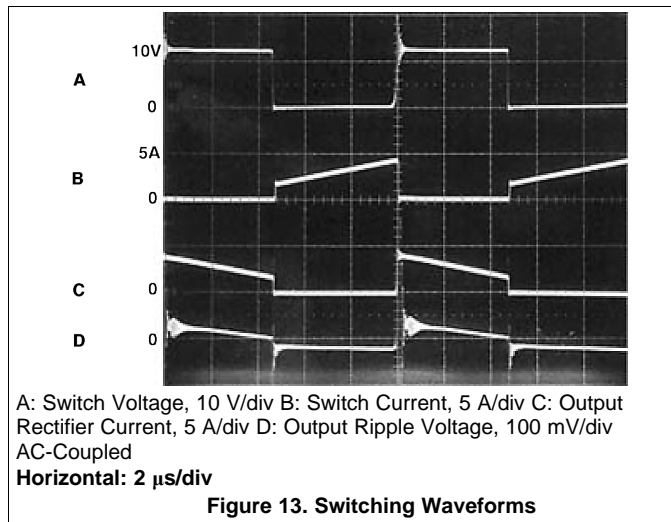

Figure 12. Short Circuit Frequency vs Temperature

Typical Characteristics (continued)



7 Detailed Description

7.1 Overview

The LM2587 is ideally suited for use in the flyback regulator topology. The flyback regulator can produce a single output voltage, such as the one shown in [Figure 15](#), or multiple output voltages. In [Figure 15](#), the flyback regulator generates an output voltage that is inside the range of the input voltage. This feature is unique to flyback regulators and cannot be duplicated with buck or boost regulators.

The operation of a flyback regulator is as follows (refer to [Figure 15](#)): when the switch is on, current flows through the primary winding of the transformer, T1, storing energy in the magnetic field of the transformer. Note that the primary and secondary windings are out of phase, so no current flows through the secondary when current flows through the primary. When the switch turns off, the magnetic field collapses, reversing the voltage polarity of the primary and secondary windings. Now rectifier D1 is forward biased and current flows through it, releasing the energy stored in the transformer. This produces voltage at the output.

The output voltage is controlled by modulating the peak switch current. This is done by feeding back a portion of the output voltage to the error amp, which amplifies the difference between the feedback voltage and a 1.23-V reference. The error amp output voltage is compared to a ramp voltage proportional to the switch current (in other words, inductor current during the switch on time). The comparator terminates the switch on time when the two voltages are equal, thereby controlling the peak switch current to maintain a constant output voltage.

As shown in [Figure 15](#), the LM2587 can be used as a flyback regulator by using a minimum number of external components. The switching waveforms of this regulator are shown in [Figure 13](#). Typical Performance Characteristics observed during the operation of this circuit are shown in [Figure 14](#).

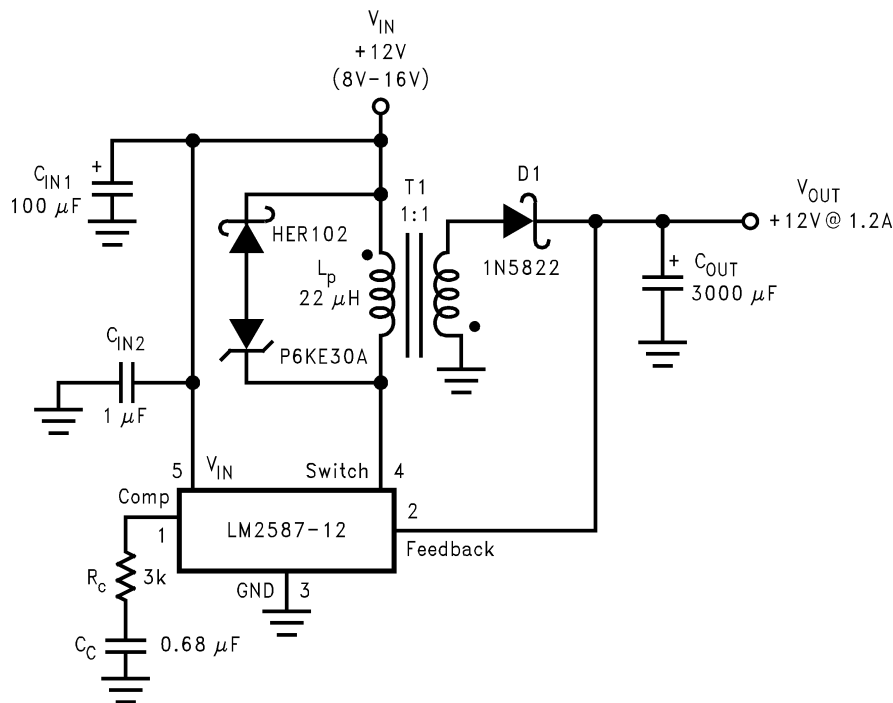
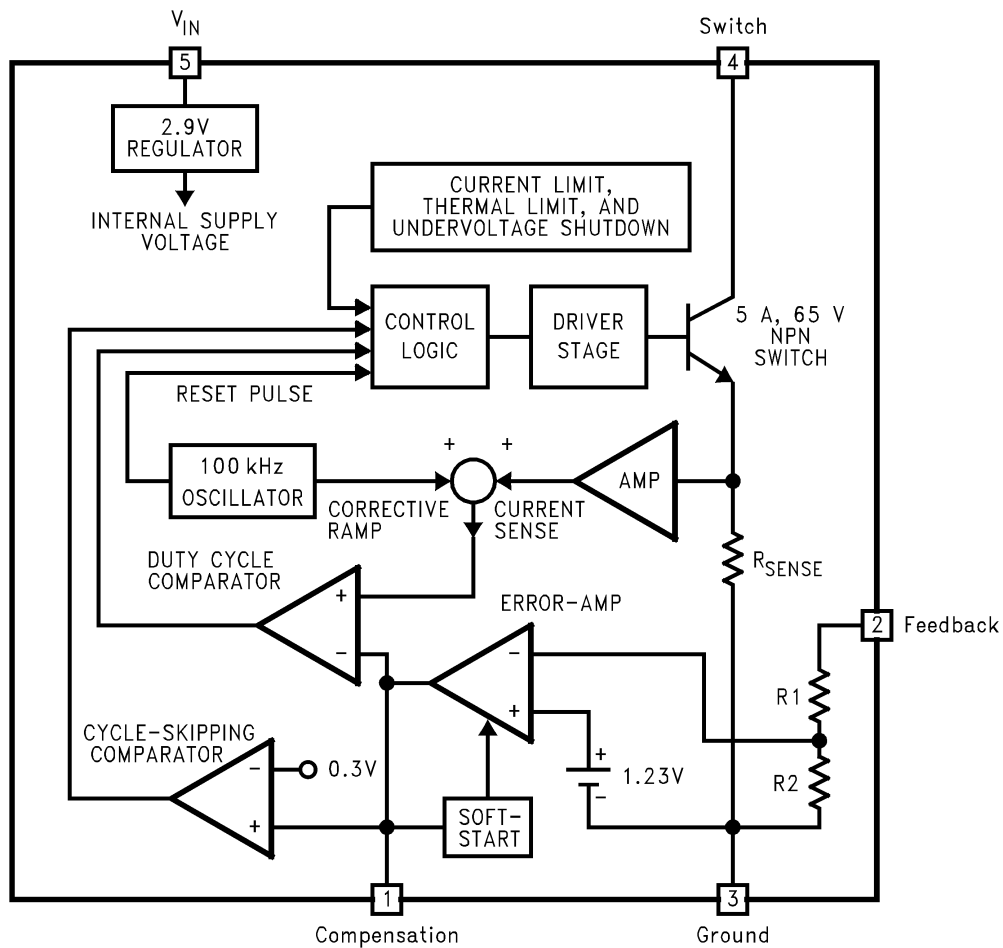

Figure 15. 12-V Flyback Regulator Design Example

7.2 Functional Block Diagram

For Fixed Versions 3.3 V, R1 = 3.4 k, R2 = 2 k, 5 V, R1 = 6.15 k, R2 = 2k 12V, R1 = 8.73 k, R2 = 1 k. For Adj. Version R1 = Short (0Ω), R2 = Open



For Fixed Versions 3.3 V, R1 = 3.4 k, R2 = 2 k, 5 V, R1 = 6.15 k, R2 = 2k 12V, R1 = 8.73 k, R2 = 1 k. For Adj. Version R1 = Short (0 Ω), R2 = Open

7.3 Feature Description

7.3.1 Step-Up (Boost) Regulator Operation

Figure 16 shows the LM2587 used as a step-up (boost) regulator. This is a switching regulator that produces an output voltage greater than the input supply voltage.

A brief explanation of how the LM2587 Boost Regulator works is as follows (refer to Figure 16). When the NPN switch turns on, the inductor current ramps up at the rate of V_{IN}/L , storing energy in the inductor. When the switch turns off, the lower end of the inductor flies above V_{IN} , discharging its current through diode (D) into the output capacitor (C_{OUT}) at a rate of $(V_{OUT} - V_{IN})/L$. Thus, energy stored in the inductor during the switch on time is transferred to the output during the switch off time. The output voltage is controlled by adjusting the peak switch current, as described in the section.

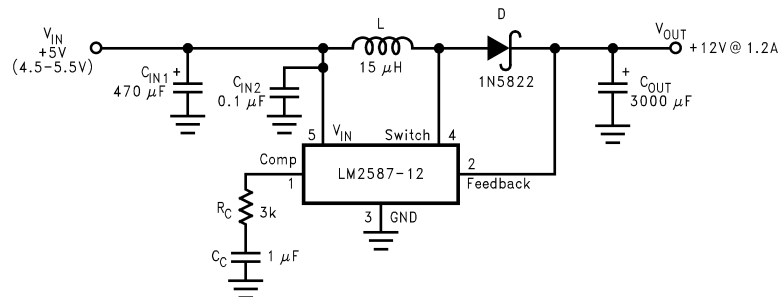

By adding a small number of external components (as shown in Figure 16), the LM2587 can be used to produce a regulated output voltage that is greater than the applied input voltage. The switching waveforms observed during the operation of this circuit are shown in . Typical performance of this regulator is shown in .

Figure 16. 12-V Boost Regulator

8 Application And Implementation

8.1 Application Information

The LM2587 series of regulators are monolithic integrated circuits specifically designed for flyback, step-up (boost), and forward converter applications. Requiring a minimum number of external components, these regulators are cost effective and simple to use.

8.2 Typical Applications

8.2.1 Typical Boost Regulator Applications

Figure 18 through Figure 21 show four typical boost applications—one fixed and three using the adjustable version of the LM2587. Each drawing contains the part number(s) and manufacturer(s) for every component. For the fixed 12-V output application, the part numbers and manufacturers' names for the inductor are listed in . For applications with different output voltages, refer to the **Switchers Made Simple** software.

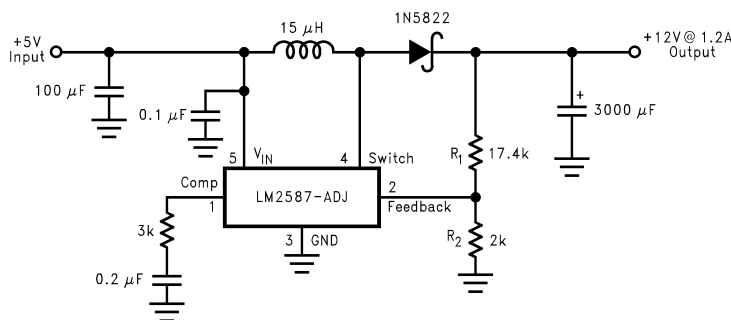

Figure 17. Boost Regulator

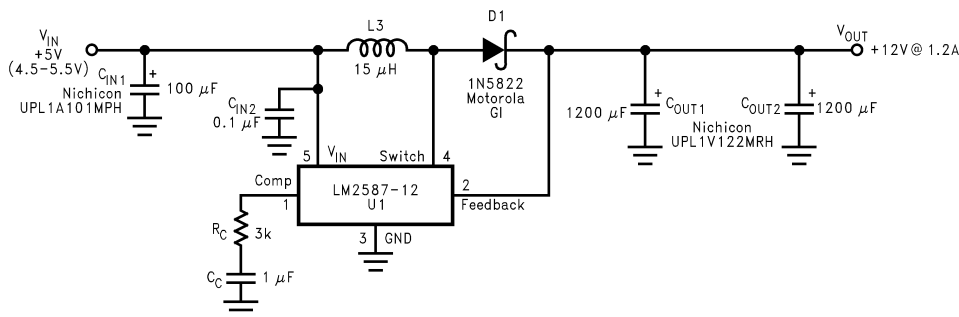

Figure 18. 5-V To 12-V Boost Regulator

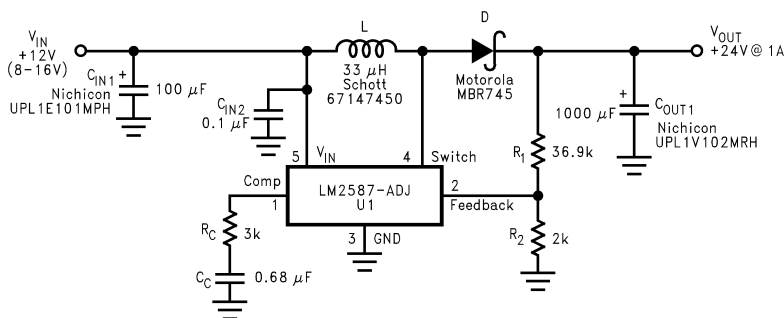

Figure 19. 12-V To 24-V Boost Regulator

Typical Applications (continued)

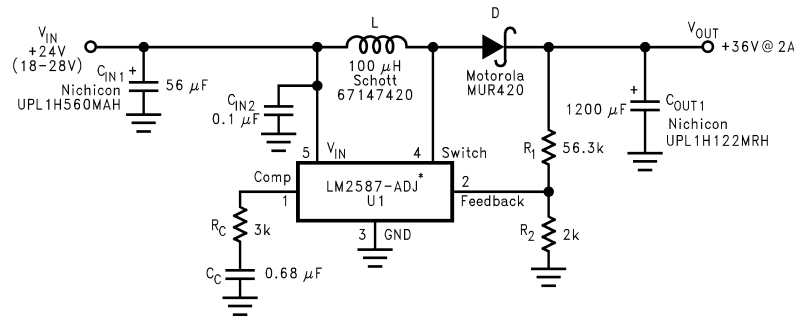
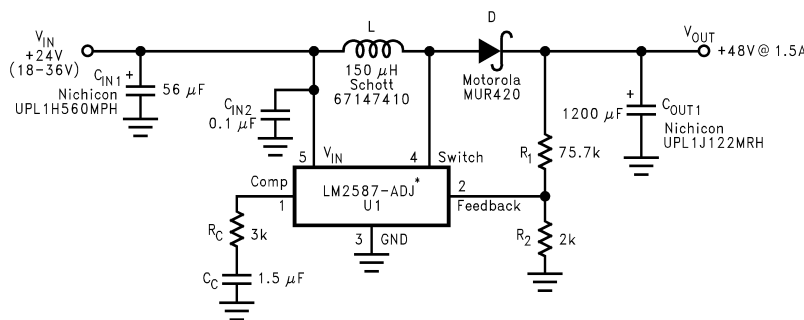

Figure 20. 24-V To 36-V Boost Regulator



*The LM2585 will require a heat sink in these applications. The size of the heat sink will depend on the maximum ambient temperature. To calculate the thermal resistance of the IC and the size of the heat sink needed, see

Figure 21. 24-V To 48-V Boost Regulator

8.2.2 Typical Flyback Regulator Applications

Figure 24 Figure 25 Figure 26 show six typical flyback applications, varying from single output to triple output. Each drawing contains the part number(s) and manufacturer(s) for every component except the transformer. For the transformer part numbers and manufacturers names, see the table in . For applications with different output voltages—requiring the LM2587-ADJ—or different output configurations that do not match the standard configurations, refer to the **Switchers Made Simple** software.

Typical Applications (continued)

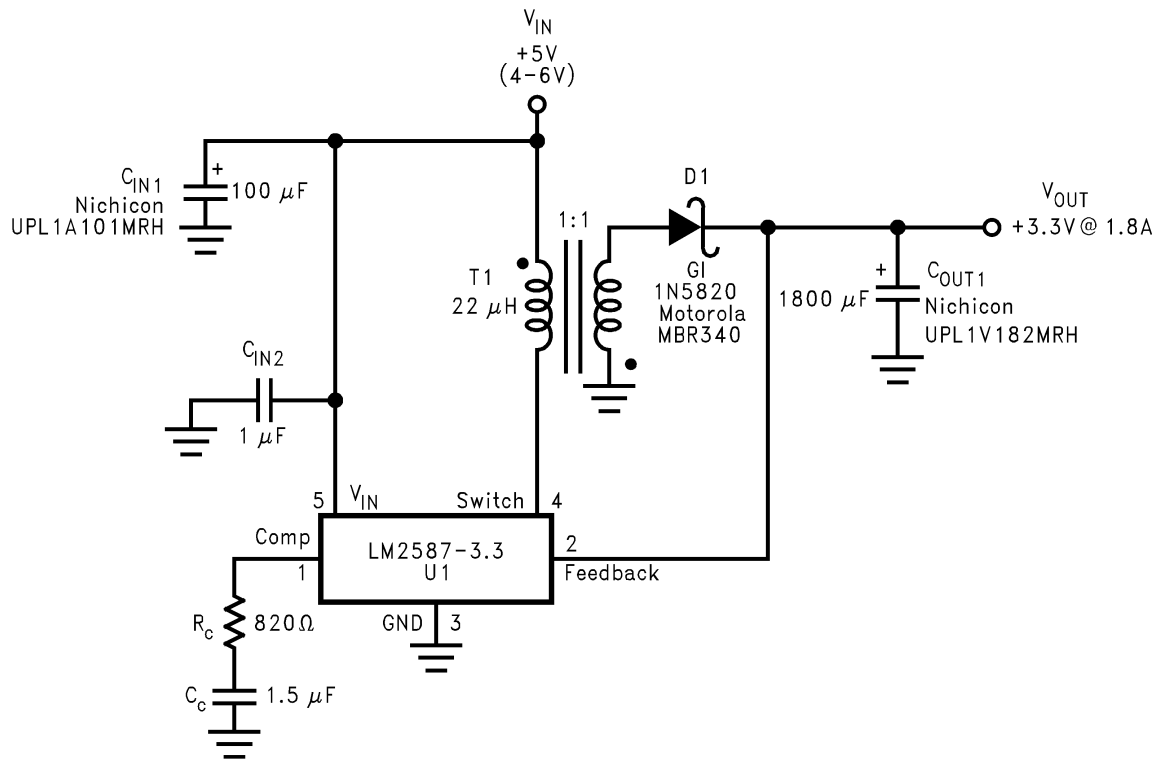

Figure 22. Single-Output Flyback Regulator

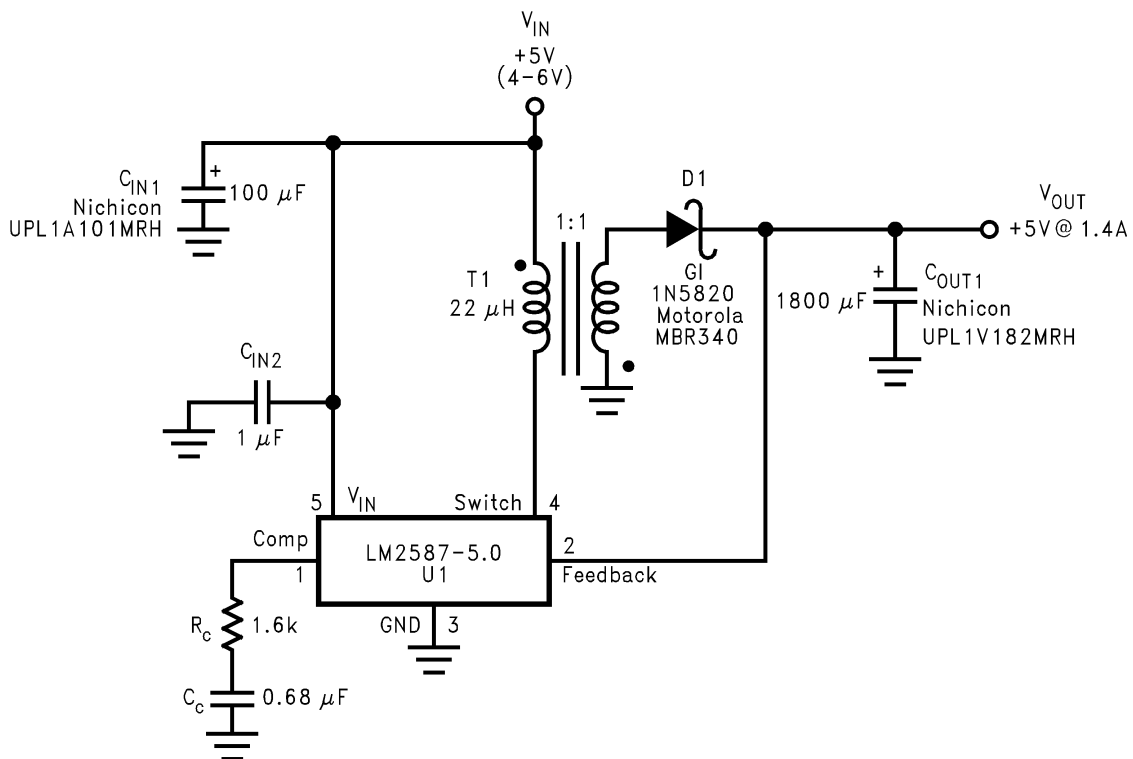

Figure 23. Single-Output Flyback Regulator

Typical Applications (continued)

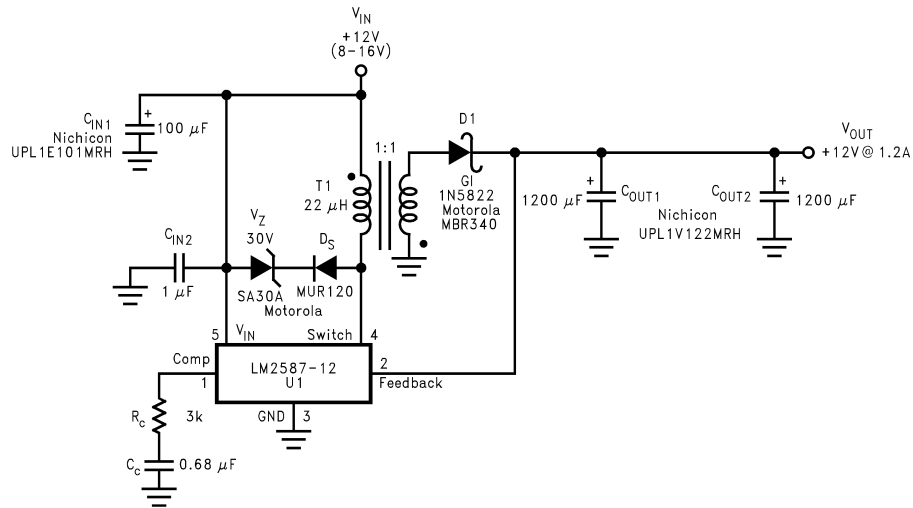

Figure 24. Single-Output Flyback Regulator

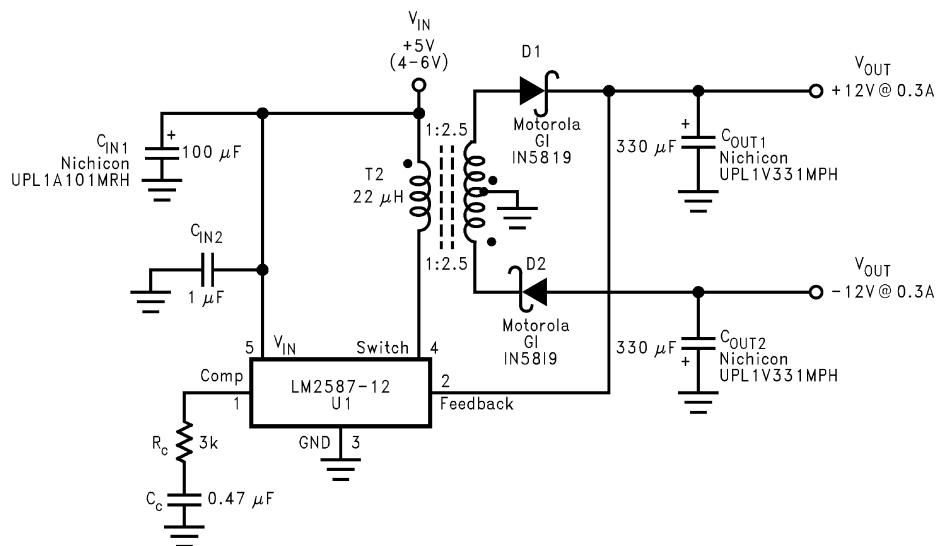

Figure 25. Dual-Output Flyback Regulator

Typical Applications (continued)

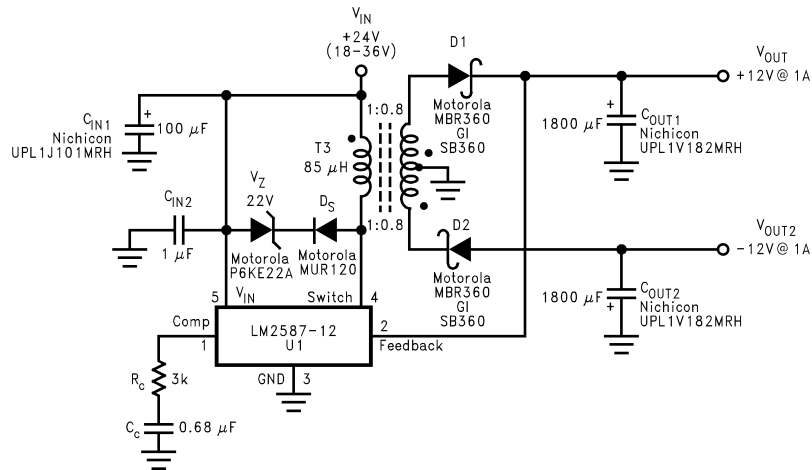

Figure 26. Dual-Output Flyback Regulator

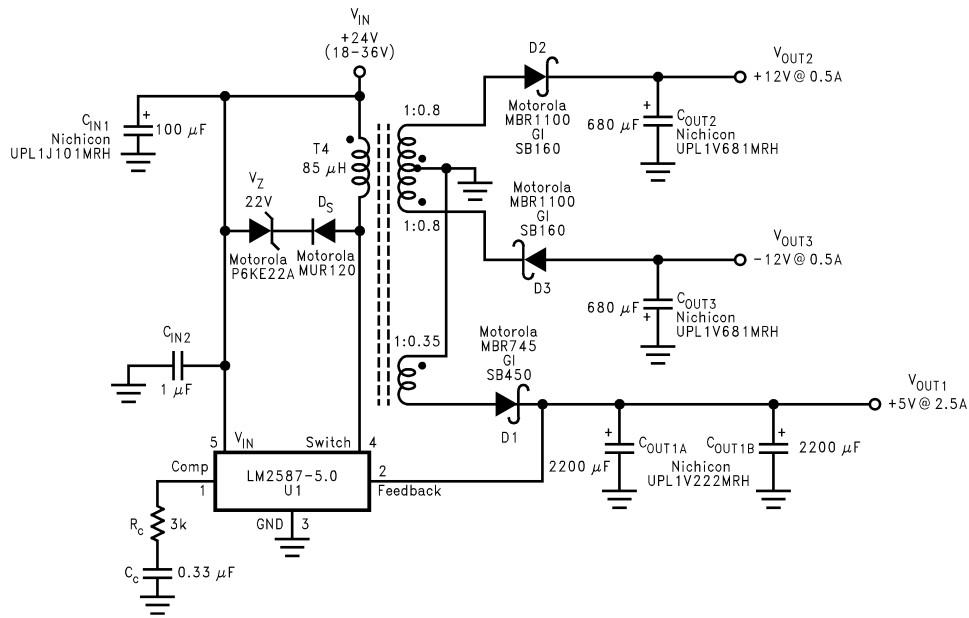

Figure 27. Triple-Output Flyback Regulator

Typical Applications (continued)

8.2.2.1 Transformer Selection (T)

lists the standard transformers available for flyback regulator applications. Included in the table are the turns ratio(s) for each transformer, as well as the output voltages, input voltage ranges, and the maximum load currents for each circuit.

Table 1. Transformer Selection Table

Applications			Figure 24	Figure 25	Figure 26	Figure 27
Transformers	T1	T1	T1	T2	T3	T4
V _{IN}	4V–6V	4V–6V	8V–16V	4V–6V	18V–36V	18V–36V
V _{OUT1}	3.3V	5V	12V	12V	12V	5V
I _{OUT1} (Max)	1.8A	1.4A	1.2A	0.3A	1A	2.5A
N ₁	1	1	1	2.5	0.8	0.35
V _{OUT2}				-12V	-12V	12V
I _{OUT2} (Max)				0.3A	1A	0.5A
N ₂				2.5	0.8	0.8
V _{OUT3}						-12V
I _{OUT3} (Max)						0.5A
N ₃						0.8

Table 2. Transformer Manufacturer Guide

Transformer Type	Manufacturers' Part Numbers					
	Coilcraft (1)	Coilcraft (1) Surface Mount	Pulse (2) Surface Mount	Pulse (2)	Renco (3)	Schott (4)
T5	Q4338-B	Q4437-B	PE-68413	—	RL-5532	67140890
T6	Q4339-B	Q4438-B	PE-68414	—	RL-5533	67140900
T7	S6000-A	S6057-A	—	PE-68482	RL-5751	26606

- (1) Coilcraft Inc. Phone: (800) 322-2645 www.coilcraft.com
- (2) Pulse Engineering Inc. Phone: (619) 674-8100 www.digikey.com
- (3) Renco Electronics Inc. Phone: (800) 645-5828 www.cdiweb.com/rengo
- (4) Schott Corp. Phone: (612) 475-1173 www.schottcorp.com/

8.2.2.2 Transformer Footprints

through Figure 58 show the footprints of each transformer, listed in .

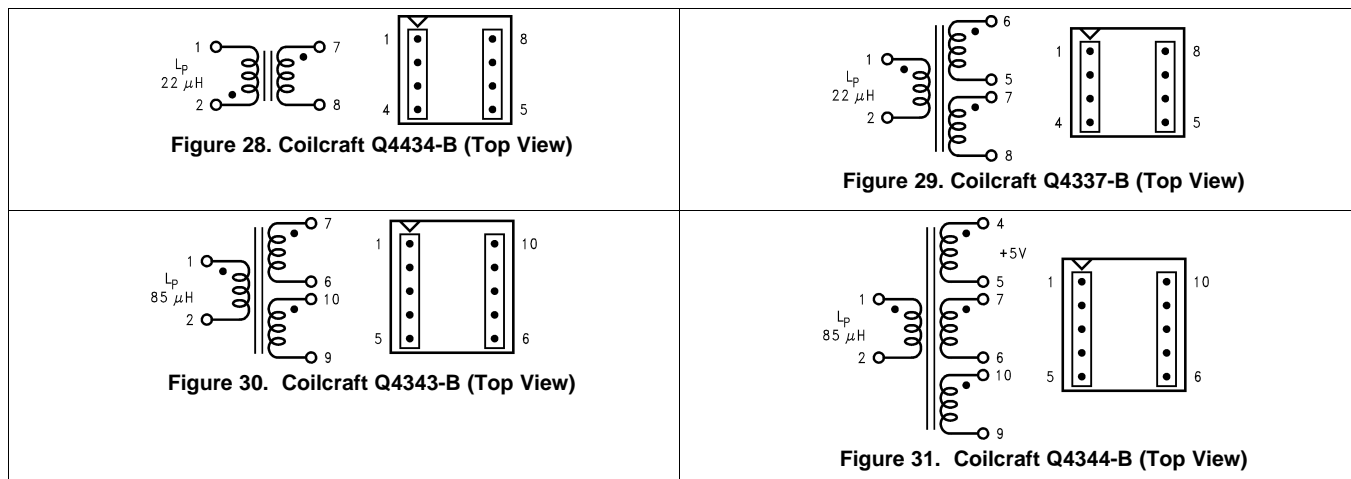

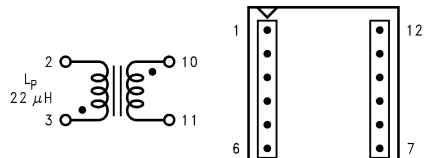

Figure 32. Coilcraft Q4435-B (Surface Mount) (Top View)

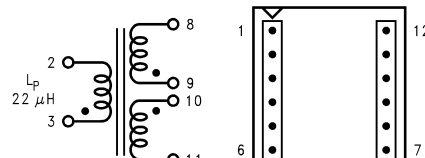

Figure 33. Coilcraft Q4436-B (Surface Mount) (Top View)

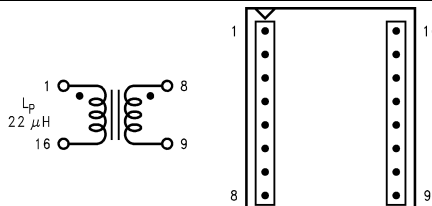

Figure 34. Pulse PE-68411 (Surface Mount) (Top View)

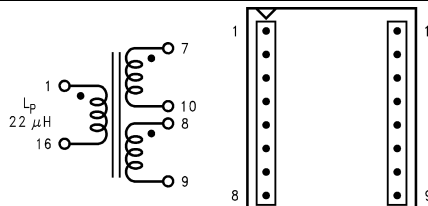

Figure 35. Pulse PE-68412 (Surface Mount) (Top View)

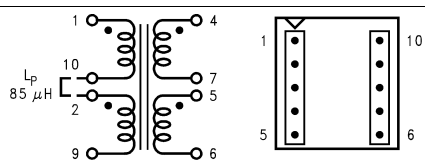

Figure 36. Pulse PE-68421 (Surface Mount) (Top View)

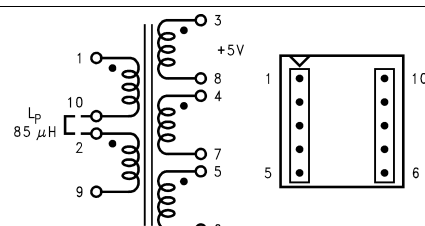

Figure 37. Pulse PE-68422 (Surface Mount) (Top View)

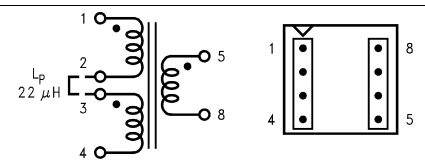

Figure 38. Renco RL-5530 (Top View)

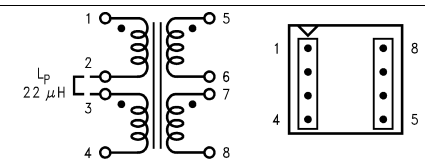

Figure 39. Renco RL-5531 (Top View)

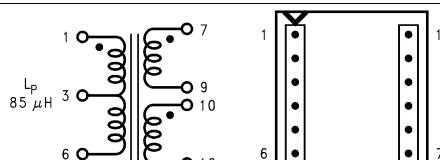

Figure 40. Renco RL-5534 (Top View)

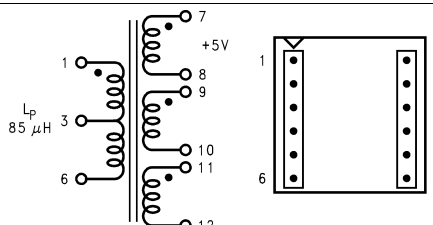

Figure 41. Renco RL-5535 (Top View)

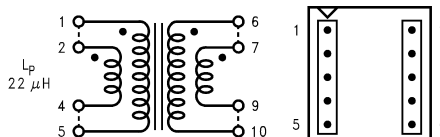

Figure 42. Schott 67141450 (Top View)

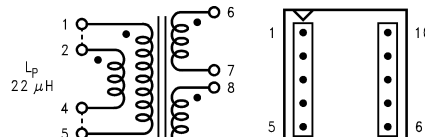

Figure 43. Schott 67140860 (Top View)

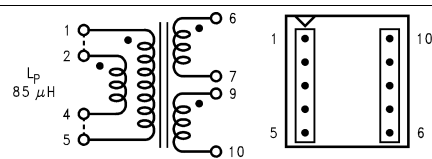

Figure 44. Schott 67140920 (Top View)

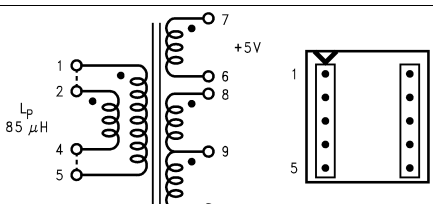

Figure 45. Schott 67140930 (Top View)

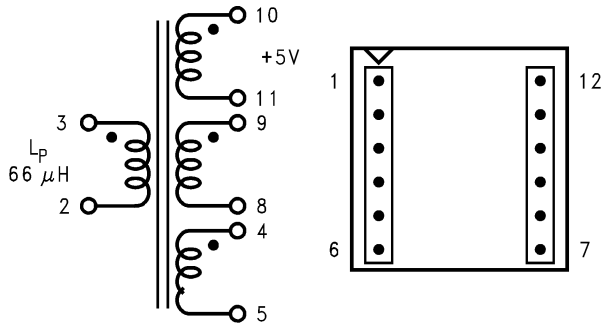

Figure 46. Coilcraft Q4437-B (Top View) (Surface Mount)

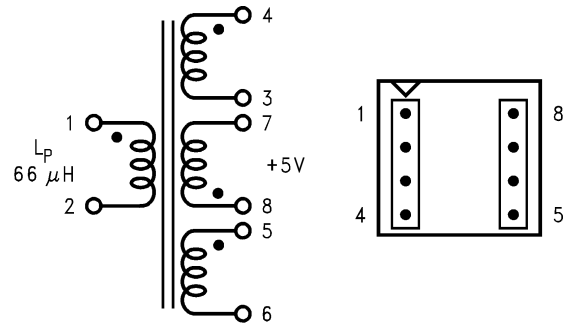

Figure 47. Coilcraft Q4338-B (Top View)

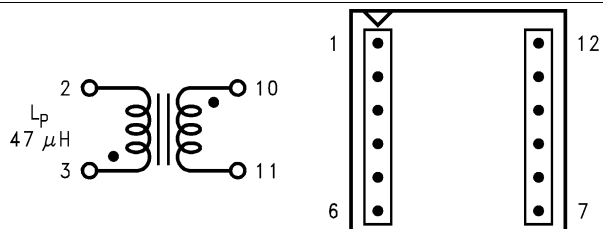

Figure 48. Coilcraft S6057-A (Top View) (Surface Mount)

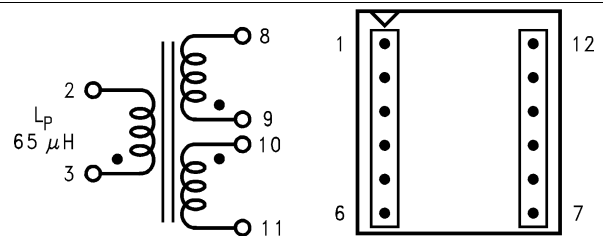

Figure 49. Coilcraft Q4438-B (Top View) (Surface Mount)

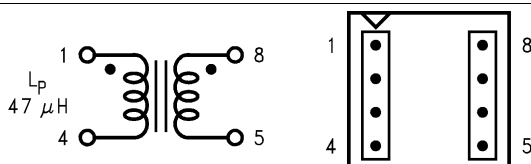

Figure 50. Pulse Pe-68482 (Top View)

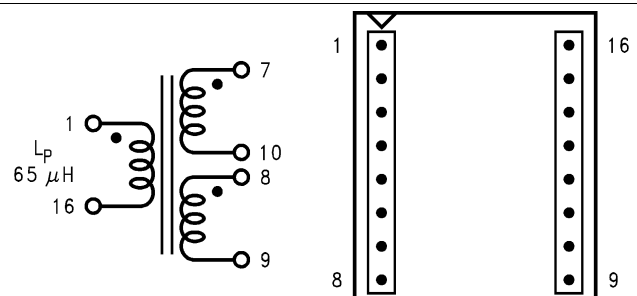

Figure 51. Pulse Pe-68414 (Top View) (Surface Mount)

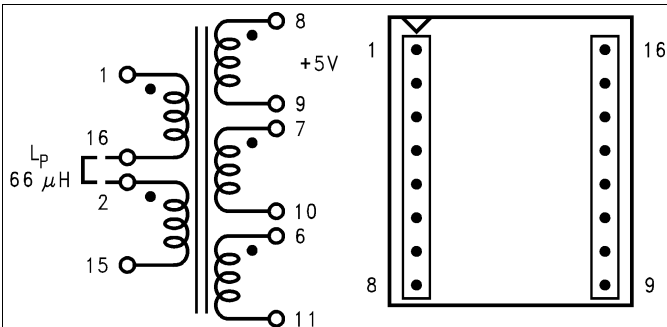

Figure 52. Pulse Pe-68413 (Top View) (Surface Mount)

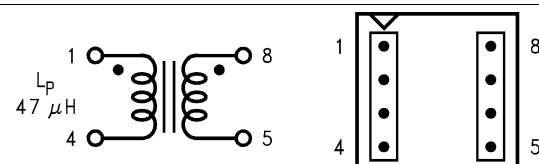

Figure 53. Renco RI-5751 (Top View)

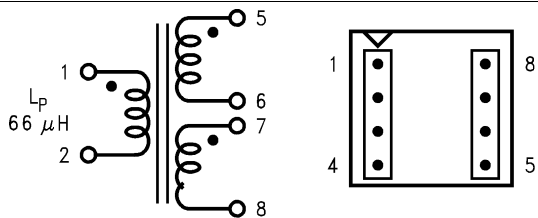

Figure 54. Renco RI-5533 (Top View)

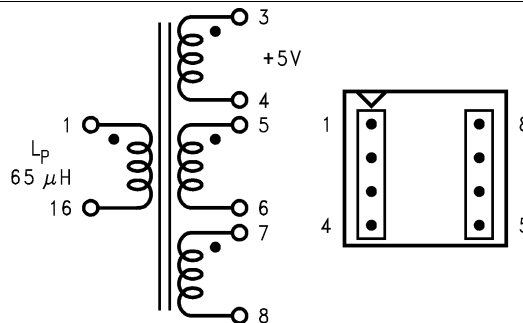

Figure 55. Renco RI-5532 (Top View)

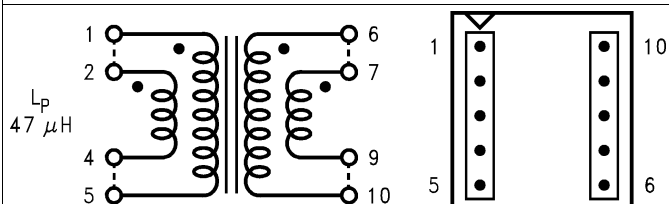

Figure 56. Schott 26606 (Top View)

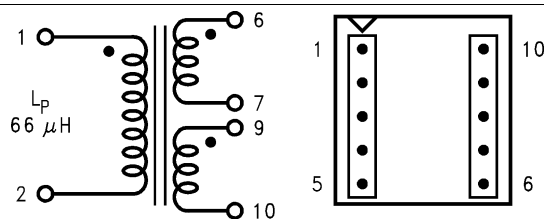

Figure 57. Schott 67140900 (Top View)

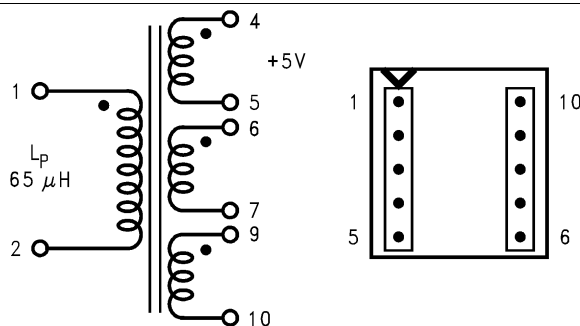

Figure 58. Schott 67140890 (Top View)

8.2.3 Design Requirements

Table 3 contains a table of standard inductors, by part number and corresponding manufacturer, for the fixed output regulator of Figure 18.

Table 3. Inductor Selection Table

Coilcraft ⁽¹⁾	Pulse ⁽²⁾	Renco ⁽³⁾	Schott ⁽⁴⁾
R4793-A	PE-53900	RL-5472-5	67146520

(1) Coilcraft Inc., Phone: (800) 322-2645/1102 Silver Lake Road, Cary, IL 60013: Fax: (708) 639-1469

(2) Pulse Engineering Inc., Phone: (619) 674-8100/12220 World Trade Drive, San Diego, CA 92128: Fax: (619) 674-8262

(3) Renco Electronics Inc., Phone: (800) 645-5828/60 Jeffryn Blvd. East, Deer Park, NY 11729: Fax: (516) 586-5562

(4) Schott Corp., Phone: (612) 475-1173/1000 Parkers Lane Road, Wayzata, MN 55391: Fax: (612) 475-1786

8.2.4 Detailed Design Procedure

8.2.4.1 Custom Design With Webench® Tools

Click [here](#) to create a custom design using the LM2587 device with the WEBENCH® Power Designer.

1. Start by entering the input voltage (V_{IN}), output voltage (V_{OUT}), and output current (I_{OUT}) requirements.
2. Optimize the design for key parameters such as efficiency, footprint, and cost using the optimizer dial.
3. Compare the generated design with other possible solutions from Texas Instruments.

The WEBENCH Power Designer provides a customized schematic along with a list of materials with real-time pricing and component availability.

In most cases, these actions are available:

- Run electrical simulations to see important waveforms and circuit performance
- Run thermal simulations to understand board thermal performance
- Export customized schematic and layout into popular CAD formats
- Print PDF reports for the design, and share the design with colleagues

Get more information about WEBENCH tools at www.ti.com/WEBENCH.

8.2.4.2 Programming Output Voltage (Selecting R_1 And R_2)

Referring to the adjustable regulator in Figure 17, the output voltage is programmed by the resistors R_1 and R_2 by the following formula:

$$V_{OUT} = V_{REF} (1 + R_1/R_2) \quad \text{where } V_{REF} = 1.23V \tag{1}$$

Resistors R_1 and R_2 divide the output voltage down so that it can be compared with the 1.23V internal reference. With R_2 between 1k and 5k, R_1 is:

$$R_1 = R_2 (V_{OUT}/V_{REF} - 1) \quad \text{where } V_{REF} = 1.23V \tag{2}$$

For best temperature coefficient and stability with time, use 1% metal film resistors.

8.2.4.3 Short Circuit Condition

Due to the inherent nature of boost regulators, when the output is shorted (see Figure 17), current flows directly from the input, through the inductor and the diode, to the output, bypassing the switch. The current limit of the switch *does not* limit the output current for the entire circuit. To protect the load and prevent damage to the switch, the current must be externally limited, either by the input supply or at the output with an external current limit circuit. The external limit should be set to the maximum switch current of the device, which is 5A.

In a flyback regulator application (Figure 59), using the standard transformers, the LM2587 will survive a short circuit to the main output. When the output voltage drops to 80% of its nominal value, the frequency will drop to 25 kHz. With a lower frequency, off times are larger. With the longer off times, the transformer can release all of its stored energy before the switch turns back on. Hence, the switch turns on initially with zero current at its collector. In this condition, the switch current limit will limit the peak current, saving the device.

8.2.4.4 Flyback Regulator Input Capacitors

A flyback regulator draws discontinuous pulses of current from the input supply. Therefore, there are two input capacitors needed in a flyback regulator; one for energy storage and one for filtering (see Figure 59). Both are required due to the inherent operation of a flyback regulator. To keep a stable or constant voltage supply to the LM2587, a storage capacitor ($\geq 100 \mu\text{F}$) is required. If the input source is a rectified DC supply and/or the application has a wide temperature range, the required rms current rating of the capacitor might be very large. This means a larger value of capacitance or a higher voltage rating will be needed of the input capacitor. The storage capacitor will also attenuate noise which may interfere with other circuits connected to the same input supply voltage.

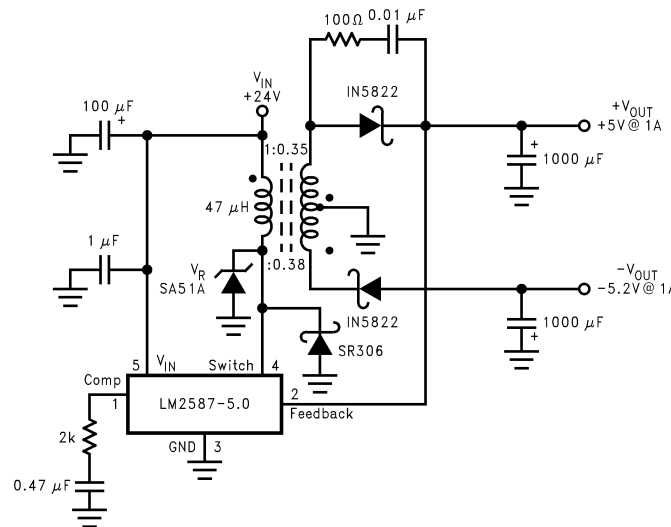

Figure 59. Flyback Regulator

In addition, a small bypass capacitor is required due to the noise generated by the input current pulses. To eliminate the noise, insert a $1.0 \mu\text{F}$ ceramic capacitor between V_{IN} and ground as close as possible to the device.

8.2.4.5 Switch Voltage Limits

In a flyback regulator, the maximum steady-state voltage appearing at the switch, when it is off, is set by the transformer turns ratio, N , the output voltage, V_{OUT} , and the maximum input voltage, $V_{\text{IN}} (\text{Max})$:

$$V_{\text{SW(OFF)}} = V_{\text{IN}} (\text{Max}) + (V_{\text{OUT}} + V_{\text{F}})/N \quad (3)$$

where V_{F} is the forward biased voltage of the output diode, and is 0.5V for Schottky diodes and 0.8V for ultra-fast recovery diodes (typically). In certain circuits, there exists a voltage spike, V_{LL} , superimposed on top of the steady-state voltage (see Figure 13, waveform A). Usually, this voltage spike is caused by the transformer leakage inductance and/or the output rectifier recovery time. To “clamp” the voltage at the switch from exceeding its maximum value, a transient suppressor in series with a diode is inserted across the transformer primary (as shown in the circuit on the front page and other flyback regulator circuits throughout the datasheet). The schematic in Figure 59 shows another method of clamping the switch voltage. A single voltage transient suppressor (the SA51A) is inserted at the switch pin. This method clamps the total voltage across the switch, not just the voltage across the primary.

If poor circuit layout techniques are used (see the Layout Guidelines section), negative voltage transients may appear on the Switch pin (pin 4). Applying a negative voltage (with respect to the IC's ground) to any monolithic IC pin causes erratic and unpredictable operation of that IC. This holds true for the LM2587 IC as well. When used in a flyback regulator, the voltage at the Switch pin (pin 4) can go negative when the switch turns on. The “ringing” voltage at the switch pin is caused by the output diode capacitance and the transformer leakage inductance forming a resonant circuit at the secondary(ies). The resonant circuit generates the “ringing” voltage, which gets reflected back through the transformer to the switch pin. There are two common methods to avoid this problem. One is to add an RC snubber around the output rectifier(s), as in Figure 59. The values of the resistor and the capacitor must be chosen so that the voltage at the Switch pin does not drop below -0.4V . The resistor may range in value between 10Ω and $1 \text{ k}\Omega$, and the capacitor will vary from $0.001 \mu\text{F}$ to $0.1 \mu\text{F}$. Adding a snubber will (slightly) reduce the efficiency of the overall circuit.

The other method to reduce or eliminate the “ringing” is to insert a Schottky diode clamp between pins 4 and 3 (ground), also shown in [Figure 59](#). This prevents the voltage at pin 4 from dropping below $-0.4V$. The reverse voltage rating of the diode must be greater than the switch off voltage.

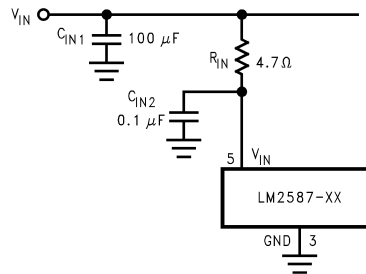

Figure 60. Input Line Filter

8.2.4.6 Output Voltage Limitations

The maximum output voltage of a boost regulator is the maximum switch voltage minus a diode drop. In a flyback regulator, the maximum output voltage is determined by the turns ratio, N , and the duty cycle, D , by the equation:

$$V_{OUT} \approx N \times V_{IN} \times D / (1 - D) \quad (4)$$

The duty cycle of a flyback regulator is determined by the following equation:

$$D = \frac{V_{OUT} + V_F}{N(V_{IN} - V_{SAT}) + V_{OUT} + V_F} \approx \frac{V_{OUT}}{N(V_{IN}) + V_{OUT}} \quad (5)$$

Theoretically, the maximum output voltage can be as large as desired—just keep increasing the turns ratio of the transformer. However, there exists some physical limitations that prevent the turns ratio, and thus the output voltage, from increasing to infinity. The physical limitations are capacitances and inductances in the LM2587 switch, the output diode(s), and the transformer—such as reverse recovery time of the output diode (mentioned above).

8.2.4.7 Noisy Input Line Condition)

A small, low-pass RC filter should be used at the input pin of the LM2587 if the input voltage has an unusual large amount of transient noise, such as with an input switch that bounces. The circuit in [Figure 60](#) demonstrates the layout of the filter, with the capacitor placed from the input pin to ground and the resistor placed between the input supply and the input pin. Note that the values of R_{IN} and C_{IN} shown in the schematic are good enough for most applications, but some readjusting might be required for a particular application. If efficiency is a major concern, replace the resistor with a small inductor (say $10 \mu H$ and rated at 100 mA).

8.2.4.8 Stability

All current-mode controlled regulators can suffer from an instability, known as subharmonic oscillation, if they operate with a duty cycle above 50%. To eliminate subharmonic oscillations, a minimum value of inductance is required to ensure stability for all boost and flyback regulators. The minimum inductance is given by:

$$L(\text{Min}) = \frac{2.92 [(V_{IN}(\text{Min}) - V_{SAT}) \times (2D(\text{Max}) - 1)]}{1 - D(\text{Max})} (\mu H)$$

where

- V_{SAT} is the switch saturation voltage and can be found in the Characteristic Curves. (6)

8.3 Additional Application Examples

8.3.1 Test Circuits

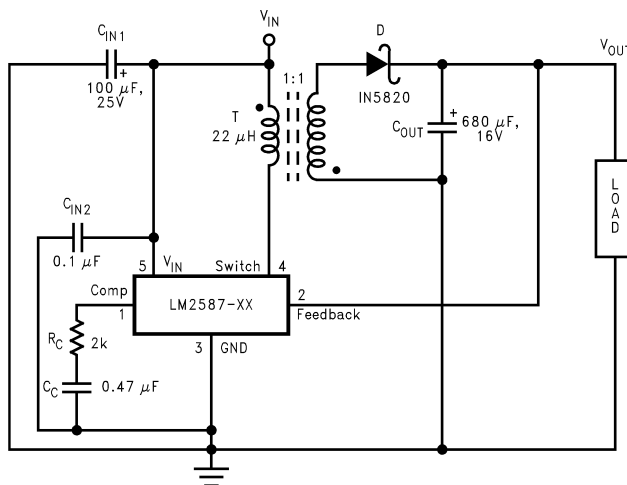

C_{IN1} —100 μ F, 25V Aluminum Electrolytic C_{IN2} —0.1 μ F Ceramic T —22 μ H, 1:1 Schott #67141450D—1N5820 C_{OUT} —680 μ F, 16V Aluminum Electrolytic C_C —0.47 μ F Ceramic R_C —2k

Figure 61. LM2587-3.3 and LM2587-5.0 Test Circuit

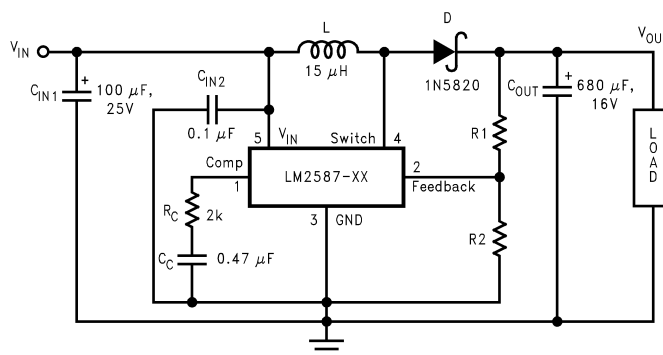

C_{IN1} —100 μ F, 25V Aluminum Electrolytic C_{IN2} —0.1 μ F Ceramic L —15 μ H, Renco #RL-5472-5D—1N5820 C_{OUT} —680 μ F, 16V Aluminum Electrolytic C_C —0.47 μ F Ceramic R_C —2k For 12V Devices: R_1 = Short (0 Ω) and R_2 = Open For ADJ Devices: R_1 = 48.75k, \pm 0.1% and R_2 = 5.62k, \pm 1%

Figure 62. LM2587-12 and LM2587-ADJ Test Circuit

9 Layout

9.1 Layout Guidelines

As in any switching regulator, layout is very important. Rapidly switching currents associated with wiring inductance generate voltage transients which can cause problems. For minimal inductance and ground loops, keep the length of the leads and traces as short as possible. Use single point grounding or ground plane construction for best results. Separate the signal grounds from the power grounds (as indicated in [Figure 63](#)). When using the adjustable version, physically locate the programming resistors as near the regulator IC as possible, to keep the sensitive feedback wiring short.

9.2 Layout Example

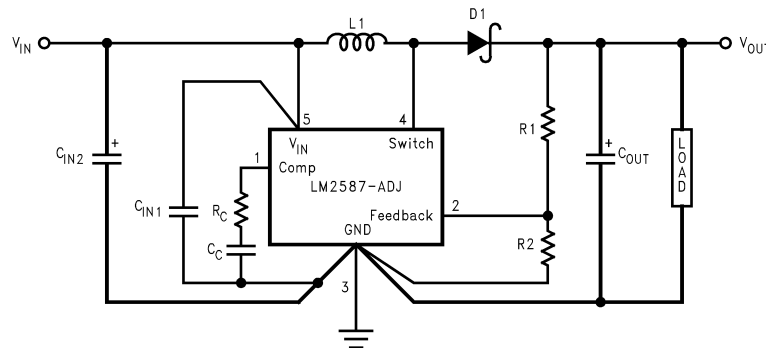

Figure 63. Circuit Board Layout

9.3 Heat Sink/Thermal Considerations

In many cases, no heat sink is required to keep the LM2587 junction temperature within the allowed operating range. For each application, to determine whether or not a heat sink will be required, the following must be identified:

- 1) Maximum ambient temperature (in the application).
- 2) Maximum regulator power dissipation (in the application).
- 3) Maximum allowed junction temperature (125°C for the LM2587). For a safe, conservative design, a temperature approximately 15°C cooler than the maximum junction temperature should be selected (110°C).
- 4) LM2587 package thermal resistances θ_{JA} and θ_{JC} (given in the Electrical Characteristics).

Total power dissipated (P_D) by the LM2587 can be estimated as follows:

Heat Sink/Thermal Considerations (continued)

Boost:

$$P_D = 0.15\Omega \times \left(\frac{I_{LOAD}}{1-D} \right)^2 \times D + \frac{I_{LOAD}}{50 \times (1-D)} \times D \times V_{IN}$$

Flyback:

$$P_D = 0.15\Omega \times \left(\frac{N \times \Sigma I_{LOAD}}{1-D} \right)^2 \times D + \frac{N \times \Sigma I_{LOAD}}{50 \times (1-D)} \times D \times V_{IN} \quad (7)$$

V_{IN} is the minimum input voltage, V_{OUT} is the output voltage, N is the transformer turns ratio, D is the duty cycle, and I_{LOAD} is the maximum load current (and ΣI_{LOAD} is the sum of the maximum load currents for multiple-output flyback regulators). The duty cycle is given by:

Boost:

$$D = \frac{V_{OUT} + V_F - V_{IN}}{V_{OUT} + V_F - V_{SAT}} \approx \frac{V_{OUT} - V_{IN}}{V_{OUT}}$$

Flyback:

$$D = \frac{V_{OUT} + V_F}{N(V_{IN} - V_{SAT}) + V_{OUT} + V_F} \approx \frac{V_{OUT}}{N(V_{IN}) + V_{OUT}}$$

where

- V_F is the forward biased voltage of the diode and is typically 0.5V for Schottky diodes and 0.8V for fast recovery diodes.
- V_{SAT} is the switch saturation voltage and can be found in the Characteristic Curves. (8)

When no heat sink is used, the junction temperature rise is:

$$\Delta T_J = P_D \times \theta_{JA} \quad (9)$$

Adding the junction temperature rise to the maximum ambient temperature gives the actual operating junction temperature:

$$T_J = \Delta T_J + T_A \quad (10)$$

If the operating junction temperature exceeds the maximum junction temperature in item 3 above, then a heat sink is required. When using a heat sink, the junction temperature rise can be determined by the following:

$$\Delta T_J = P_D \times (\theta_{JC} + \theta_{Interface} + \theta_{Heat\ Sink}) \quad (11)$$

Again, the operating junction temperature will be:

$$T_J = \Delta T_J + T_A \quad (12)$$

As before, if the maximum junction temperature is exceeded, a larger heat sink is required (one that has a lower thermal resistance).

Included in the **Switchers Made Simple** design software is a more precise (non-linear) thermal model that can be used to determine junction temperature with different input-output parameters or different component values. It can also calculate the heat sink thermal resistance required to maintain the regulator junction temperature below the maximum operating temperature.

To further simplify the flyback regulator design procedure, TI is making available computer design software. Switchers Made Simple software is available on a (3½") diskette for IBM compatible computers from a TI sales office in your area or the TI WEBENCH Design Center team.

http://www.ti.com/ww/en/analog/webench/index.shtml?DCMP=hpa_sva_webench&HQS=webench-bb

Heat Sink/Thermal Considerations (continued)

9.3.1 European Magnetic Vendor Contacts

Please contact the following addresses for details of local distributors or representatives:

9.3.2 Coilcraft

21 Napier Place

Wardpark North Cumbernauld, Scotland G68 0LL Phone: +44 1236 730 595 Fax: +44 1236 730 627

9.3.3 Pulse Engineering

Dunmore Road

Tuam Co. Galway, Ireland Phone: +353 93 24 107 Fax: +353 93 24 459

10 Device and Documentation Support

10.1 Device Support

10.1.1 Third-Party Products Disclaimer

TI'S PUBLICATION OF INFORMATION REGARDING THIRD-PARTY PRODUCTS OR SERVICES DOES NOT CONSTITUTE AN ENDORSEMENT REGARDING THE SUITABILITY OF SUCH PRODUCTS OR SERVICES OR A WARRANTY, REPRESENTATION OR ENDORSEMENT OF SUCH PRODUCTS OR SERVICES, EITHER ALONE OR IN COMBINATION WITH ANY TI PRODUCT OR SERVICE.

10.1.2 Development Support

10.1.2.1 Custom Design With Webench® Tools

[Click here](#) to create a custom design using the LM2587 device with the WEBENCH® Power Designer.

1. Start by entering the input voltage (V_{IN}), output voltage (V_{OUT}), and output current (I_{OUT}) requirements.
2. Optimize the design for key parameters such as efficiency, footprint, and cost using the optimizer dial.
3. Compare the generated design with other possible solutions from Texas Instruments.

The WEBENCH Power Designer provides a customized schematic along with a list of materials with real-time pricing and component availability.

In most cases, these actions are available:

- Run electrical simulations to see important waveforms and circuit performance
- Run thermal simulations to understand board thermal performance
- Export customized schematic and layout into popular CAD formats
- Print PDF reports for the design, and share the design with colleagues

Get more information about WEBENCH tools at www.ti.com/WEBENCH.

10.2 Receiving Notification Of Documentation Updates

To receive notification of documentation updates, navigate to the device product folder on ti.com. In the upper right corner, click on *Alert me* to register and receive a weekly digest of any product information that has changed. For change details, review the revision history included in any revised document.

10.3 Community Resources

The following links connect to TI community resources. Linked contents are provided "AS IS" by the respective contributors. They do not constitute TI specifications and do not necessarily reflect TI's views; see TI's [Terms of Use](#).

TI E2E™ Online Community *TI's Engineer-to-Engineer (E2E) Community*. Created to foster collaboration among engineers. At e2e.ti.com, you can ask questions, share knowledge, explore ideas and help solve problems with fellow engineers.

Design Support *TI's Design Support* Quickly find helpful E2E forums along with design support tools and contact information for technical support.

10.4 Trademarks

E2E is a trademark of Texas Instruments.

WEBENCH, Switchers Made Simple are registered trademarks of Texas Instruments.

All other trademarks are the property of their respective owners.

10.5 Electrostatic Discharge Caution



This integrated circuit can be damaged by ESD. Texas Instruments recommends that all integrated circuits be handled with appropriate precautions. Failure to observe proper handling and installation procedures can cause damage.

ESD damage can range from subtle performance degradation to complete device failure. Precision integrated circuits may be more susceptible to damage because very small parametric changes could cause the device not to meet its published specifications.

10.6 Glossary

[SLYZ022](#) — *TI Glossary*.

This glossary lists and explains terms, acronyms, and definitions.

11 Mechanical, Packaging, and Orderable Information

The following pages include mechanical, packaging, and orderable information. This information is the most current data available for the designated devices. This data is subject to change without notice and revision of this document. For browser-based versions of this data sheet, refer to the left-hand navigation.

PACKAGING INFORMATION

Orderable Device	Status (1)	Package Type	Package Drawing	Pins	Package Qty	Eco Plan (2)	Lead/Ball Finish (6)	MSL Peak Temp (3)	Op Temp (°C)	Device Marking (4/5)	Samples
LM2587S-12/NOPB	ACTIVE	DDPAK/ TO-263	KTT	5	45	Pb-Free (RoHS Exempt)	CU SN	Level-3-245C-168 HR	-40 to 125	LM2587S -12 P+	Samples
LM2587S-3.3/NOPB	ACTIVE	DDPAK/ TO-263	KTT	5	45	Pb-Free (RoHS Exempt)	CU SN	Level-3-245C-168 HR	-40 to 125	LM2587S -3.3 P+	Samples
LM2587S-5.0	NRND	DDPAK/ TO-263	KTT	5	45	TBD	Call TI	Call TI	-40 to 125	LM2587S -5.0 P+	
LM2587S-5.0/NOPB	ACTIVE	DDPAK/ TO-263	KTT	5	45	Pb-Free (RoHS Exempt)	CU SN	Level-3-245C-168 HR	-40 to 125	LM2587S -5.0 P+	Samples
LM2587S-ADJ	NRND	DDPAK/ TO-263	KTT	5	45	TBD	Call TI	Call TI	-40 to 125	LM2587S -ADJ P+	
LM2587S-ADJ/NOPB	ACTIVE	DDPAK/ TO-263	KTT	5	45	Pb-Free (RoHS Exempt)	CU SN	Level-3-245C-168 HR	-40 to 125	LM2587S -ADJ P+	Samples
LM2587SX-12/NOPB	ACTIVE	DDPAK/ TO-263	KTT	5	500	Pb-Free (RoHS Exempt)	CU SN	Level-3-245C-168 HR	-40 to 125	LM2587S -12 P+	Samples
LM2587SX-5.0/NOPB	ACTIVE	DDPAK/ TO-263	KTT	5	500	Pb-Free (RoHS Exempt)	CU SN	Level-3-245C-168 HR	-40 to 125	LM2587S -5.0 P+	Samples
LM2587SX-ADJ	NRND	DDPAK/ TO-263	KTT	5	500	TBD	Call TI	Call TI	-40 to 125	LM2587S -ADJ P+	
LM2587SX-ADJ/NOPB	ACTIVE	DDPAK/ TO-263	KTT	5	500	Pb-Free (RoHS Exempt)	CU SN	Level-3-245C-168 HR	-40 to 125	LM2587S -ADJ P+	Samples
LM2587T-12/NOPB	ACTIVE	TO-220	NDH	5	45	Pb-Free (RoHS Exempt)	CU SN	Level-1-NA-UNLIM	-40 to 125	LM2587T -12 P+	Samples
LM2587T-3.3/NOPB	ACTIVE	TO-220	NDH	5	45	Pb-Free (RoHS Exempt)	CU SN	Level-1-NA-UNLIM	-40 to 125	LM2587T -3.3 P+	Samples
LM2587T-5.0/NOPB	ACTIVE	TO-220	NDH	5	45	Pb-Free (RoHS Exempt)	CU SN	Level-1-NA-UNLIM	-40 to 125	LM2587T -5.0 P+	Samples
LM2587T-ADJ	NRND	TO-220	NDH	5	45	TBD	Call TI	Call TI	-40 to 125	LM2587T -ADJ P+	
LM2587T-ADJ/NOPB	ACTIVE	TO-220	NDH	5	45	Pb-Free (RoHS Exempt)	CU SN	Level-1-NA-UNLIM	-40 to 125	LM2587T -ADJ P+	Samples

(1) The marketing status values are defined as follows:

ACTIVE: Product device recommended for new designs.

LIFEBUY: TI has announced that the device will be discontinued, and a lifetime-buy period is in effect.

NRND: Not recommended for new designs. Device is in production to support existing customers, but TI does not recommend using this part in a new design.

PREVIEW: Device has been announced but is not in production. Samples may or may not be available.

OBSELETE: TI has discontinued the production of the device.

⁽²⁾ **RoHS:** TI defines "RoHS" to mean semiconductor products that are compliant with the current EU RoHS requirements for all 10 RoHS substances, including the requirement that RoHS substance do not exceed 0.1% by weight in homogeneous materials. Where designed to be soldered at high temperatures, "RoHS" products are suitable for use in specified lead-free processes. TI may reference these types of products as "Pb-Free".

RoHS Exempt: TI defines "RoHS Exempt" to mean products that contain lead but are compliant with EU RoHS pursuant to a specific EU RoHS exemption.

Green: TI defines "Green" to mean the content of Chlorine (Cl) and Bromine (Br) based flame retardants meet JS709B low halogen requirements of ≤ 1000 ppm threshold. Antimony trioxide based flame retardants must also meet the ≤ 1000 ppm threshold requirement.

⁽³⁾ MSL, Peak Temp. - The Moisture Sensitivity Level rating according to the JEDEC industry standard classifications, and peak solder temperature.

⁽⁴⁾ There may be additional marking, which relates to the logo, the lot trace code information, or the environmental category on the device.

⁽⁵⁾ Multiple Device Markings will be inside parentheses. Only one Device Marking contained in parentheses and separated by a "~" will appear on a device. If a line is indented then it is a continuation of the previous line and the two combined represent the entire Device Marking for that device.

⁽⁶⁾ Lead/Ball Finish - Orderable Devices may have multiple material finish options. Finish options are separated by a vertical ruled line. Lead/Ball Finish values may wrap to two lines if the finish value exceeds the maximum column width.

Important Information and Disclaimer: The information provided on this page represents TI's knowledge and belief as of the date that it is provided. TI bases its knowledge and belief on information provided by third parties, and makes no representation or warranty as to the accuracy of such information. Efforts are underway to better integrate information from third parties. TI has taken and continues to take reasonable steps to provide representative and accurate information but may not have conducted destructive testing or chemical analysis on incoming materials and chemicals. TI and TI suppliers consider certain information to be proprietary, and thus CAS numbers and other limited information may not be available for release.

In no event shall TI's liability arising out of such information exceed the total purchase price of the TI part(s) at issue in this document sold by TI to Customer on an annual basis.

NDH0005D



T05D (REV A)

KTT (R-PSFM-G5)

PLASTIC FLANGE-MOUNT PACKAGE

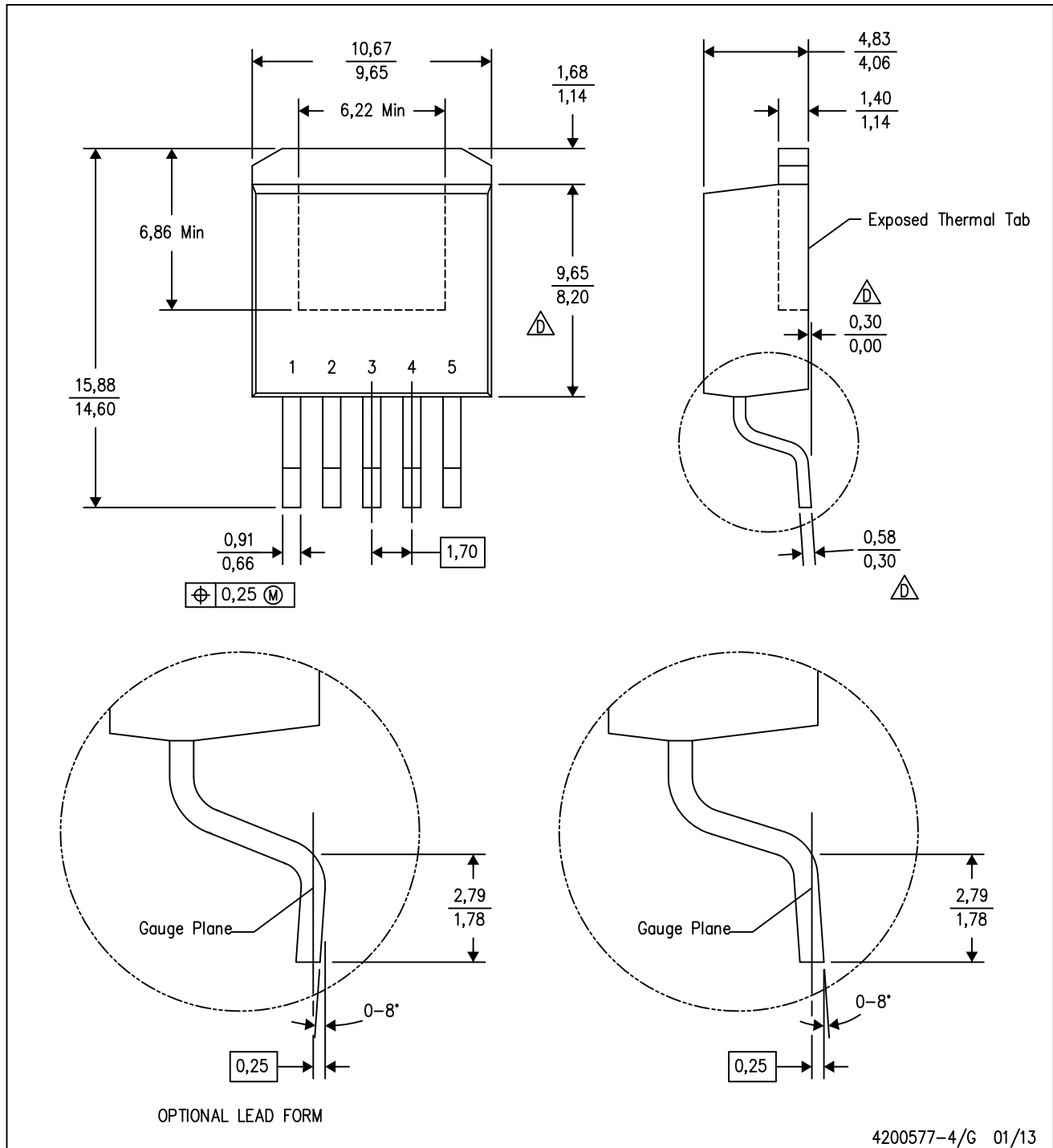

- NOTES:
- A. All linear dimensions are in millimeters.
 - B. This drawing is subject to change without notice.
 - C. Body dimensions do not include mold flash or protrusion. Mold flash or protrusion not to exceed 0.005 (0,13) per side.
- △ Falls within JEDEC TO-263 variation BA, except minimum lead thickness, maximum seating height, and minimum body length.

IMPORTANT NOTICE AND DISCLAIMER

TI PROVIDES TECHNICAL AND RELIABILITY DATA (INCLUDING DATASHEETS), DESIGN RESOURCES (INCLUDING REFERENCE DESIGNS), APPLICATION OR OTHER DESIGN ADVICE, WEB TOOLS, SAFETY INFORMATION, AND OTHER RESOURCES "AS IS" AND WITH ALL FAULTS, AND DISCLAIMS ALL WARRANTIES, EXPRESS AND IMPLIED, INCLUDING WITHOUT LIMITATION ANY IMPLIED WARRANTIES OF MERCHANTABILITY, FITNESS FOR A PARTICULAR PURPOSE OR NON-INFRINGEMENT OF THIRD PARTY INTELLECTUAL PROPERTY RIGHTS.

These resources are intended for skilled developers designing with TI products. You are solely responsible for (1) selecting the appropriate TI products for your application, (2) designing, validating and testing your application, and (3) ensuring your application meets applicable standards, and any other safety, security, or other requirements. These resources are subject to change without notice. TI grants you permission to use these resources only for development of an application that uses the TI products described in the resource. Other reproduction and display of these resources is prohibited. No license is granted to any other TI intellectual property right or to any third party intellectual property right. TI disclaims responsibility for, and you will fully indemnify TI and its representatives against, any claims, damages, costs, losses, and liabilities arising out of your use of these resources.

TI's products are provided subject to TI's Terms of Sale (www.ti.com/legal/termsofsale.html) or other applicable terms available either on ti.com or provided in conjunction with such TI products. TI's provision of these resources does not expand or otherwise alter TI's applicable warranties or warranty disclaimers for TI products.

Mailing Address: Texas Instruments, Post Office Box 655303, Dallas, Texas 75265
Copyright © 2019, Texas Instruments Incorporated